

OCIT[®]

Open Communication Interface for Road Traffic Control Systems
Offene Schnittstellen für die Straßenverkehrstechnik

OCIT-C Center to Center

TSS supply data

OCIT-C_TSS_supply_data_V2.0_R1_D1

OCIT Developer Group (ODG)&Partner

OCIT[®] Registered trade mark of AVT-STOYE, Siemens, Stührenberg, SWARCO

OCIT-C Center to Center

TSS supply data

Document: OCIT-C_TSS_supply_data_V2.0_R1_D1

Issued by: ODG & Partner

Contact: www.ocit.org

Copyright © 2018 ODG. Subject to modifications. Documents with a more recent version or revision level replace all contents of the previous versions.

Contents

1	<i>Introduction</i>	8
1.1	OCIT-C documentation.....	8
1.2	Arrangement in the level schema of a traffic signal control system with OCIT interfaces	9
2	<i>Data model</i>	9
2.1	Structure of the file intersection_config_data.xsd	10
2.2	Distribution of the planning and supply data	11
3	<i>Basic supply data for TSS</i>	15
3.1	Version information of the XML schemas	15
3.2	Header data	18
3.3	The OCITObjektHeader.....	19
3.4	Standardized objects	22
3.4.1	Digital outputs.....	22
3.4.2	Inputs.....	22
3.4.3	Power outage.....	23
3.4.4	PT reporting points	24
3.4.5	PT reporting sections	24
3.4.5.1	Data model	26
3.4.5.2	Reporting points triggered by radio	27
3.4.5.3	Reporting points triggered by sensors	27
3.4.5.4	Emergency request	28
3.4.5.5	Target effect	28
3.4.5.6	Line/route list	29
3.4.5.7	PT memory	29
3.4.6	Stage.....	31
3.4.7	Stage sequence	31
3.4.8	Stage transition.....	32
3.4.9	Framework program.....	33
3.4.9.1	Stage frame plan.....	35
3.4.9.2	Signal group frame plan	36
3.4.9.3	Traffic flow frame plan	36
3.4.10	Control clock.....	37
3.4.10.1	Week plans	37
3.4.10.2	Special intervals	38
3.4.10.3	Special days.....	39

3.4.10.4	Day plans.....	40
3.4.11	Signal group.....	42
3.4.11.1	Permitted signal patterns	44
3.4.11.2	Bit code	45
3.4.11.3	Anwurf and Abwurf transition	46
3.4.11.4	Additional transition.....	47
3.4.11.5	Lamp outputs.....	48
3.4.11.6	Special cases.....	49
3.4.12	Signal program.....	49
3.4.12.1	Signal program line	52
3.4.13	Partial intersections	53
3.4.14	Switch-on and switch-off program	53
3.4.15	Traffic-related minimum times	54
3.4.15.1	VTMindestfreigabeList	54
3.4.15.2	VTMindestgesperrtList	55
3.4.16	Incompatibility matrix	56
3.4.17	Offset time matrix	56
3.4.18	Intergreen time matrix.....	57
3.4.19	NocitList	58
3.4.19.1	Project-specific Nocit structures	58
4	<i>Versioning and data security</i>	59
4.1	Introduction.....	59
4.1.1	Versions	59
4.1.2	Process	59
4.1.2.1	Planning process.....	59
4.1.2.2	Supply to the controller	59
4.2	Frame and header	60
4.2.1	Supply data.....	60
4.2.2	Basic supply data	61
4.2.3	Control process	61
4.2.4	Restrictions	63
4.3	Metadata of the AP values	63
4.3.1	Data catalog of the AP values of a control process	63
4.3.1.1	Identification	63
4.3.1.2	Schema of definitions of AP values	63

4.3.2	Data catalog of the AP values of an intersection	65
4.4	Block formation	67
4.4.1	Standard blockformation.....	67
4.4.1.1	Part A: User supply:	67
4.4.1.2	Part B: Manufacturer supply:	67
4.4.1.3	Part C: NOCIT Data	68
4.5	Checksums	69
4.5.1	Process in the controller.....	70
4.5.2	Structure and depiction of the checksums	70
4.5.3	Checksum algorithm	72
5	<i>Communication log</i>	74
6	<i>Terms and abbreviations</i>	76
	<i>Appendix 1: Bit code of the signal patterns</i>	79

Document history

Version State	Date	Distribution List	Comments
V1.2_R1	2016-12-16	PUBLIC	Version 1.2 Issue 1
	2017-07-10	ODG internal	3.4.5 PT reporting sections, parts of text removed 3.4.5.1 Data model, new
	2018-02-15		4.4.1.1 Part A, Block 5: ASN.1 Format added
	2018-05-15		Changes and corrections
V2.0_A01	2018-05-31	PUBLIC	For OCIT-C V2.0 ODG Homepage

1 Introduction

This document describes the OCIT-C communication module for the TSS supply data.

It is aimed at all persons who deal with the implementation or application of an OCIT-C interface for the exchange of OCIT supply data in the scope of application of the traffic signal control

The TSS supply data communication module is used for supplying data to traffic signal systems.

The data is communicated using the OCIT-C protocol.

1.1 OCIT-C documentation

The present document is part of the OCIT-C definitions, which are listed in the document "OCIT-C_Release_Notes".

The specification of the OCIT-C communication module for TSS supply data comprises the document OCIT-C TSS Supply data and the schema definitions:

- *intersection_config_data.xsd* (basic supply of traffic signal controllers)
- *intersection_config_data_ap_values.xsd* (data catalog AP values)
- *intersection_config_data_block_assignment.xsd* (block assignment)
- *intersection_config_data_block_assignment.xml* (block assignment)
- *intersection_config_data_communication.xsd* (communication protocol).

In order to gain a deeper understanding, the documents OCIT-C data and OCIT-C protocol, as well as the additional OCIT-O documents are necessary:

Short name	Title	Contents
OCIT-C Release Notes	OCIT-Center to Center Release Notes	List of all OCIT-C's Specifications
OCIT-O System	Introduction to the System	Stipulations for the specification and documentation of OCIT-O interfaces.
OCIT-O Protokoll	Rules and protocols	Stipulations for the realisation of the OCIT Outstations protocols.
OCIT-O Basis	Basic Functions for Field Devices	Stipulations of the basic interfaces and device functions for devices with OCIT-O interface.
OCIT-O Lstg	Traffic signal controllers	Stipulations of the special interfaces and device functions for traffic signal controllers.

1.2 Arrangement in the level schema of a traffic signal control system with OCIT interfaces

The following diagram shows the OCIT interfaces located on the central level and on the field level.

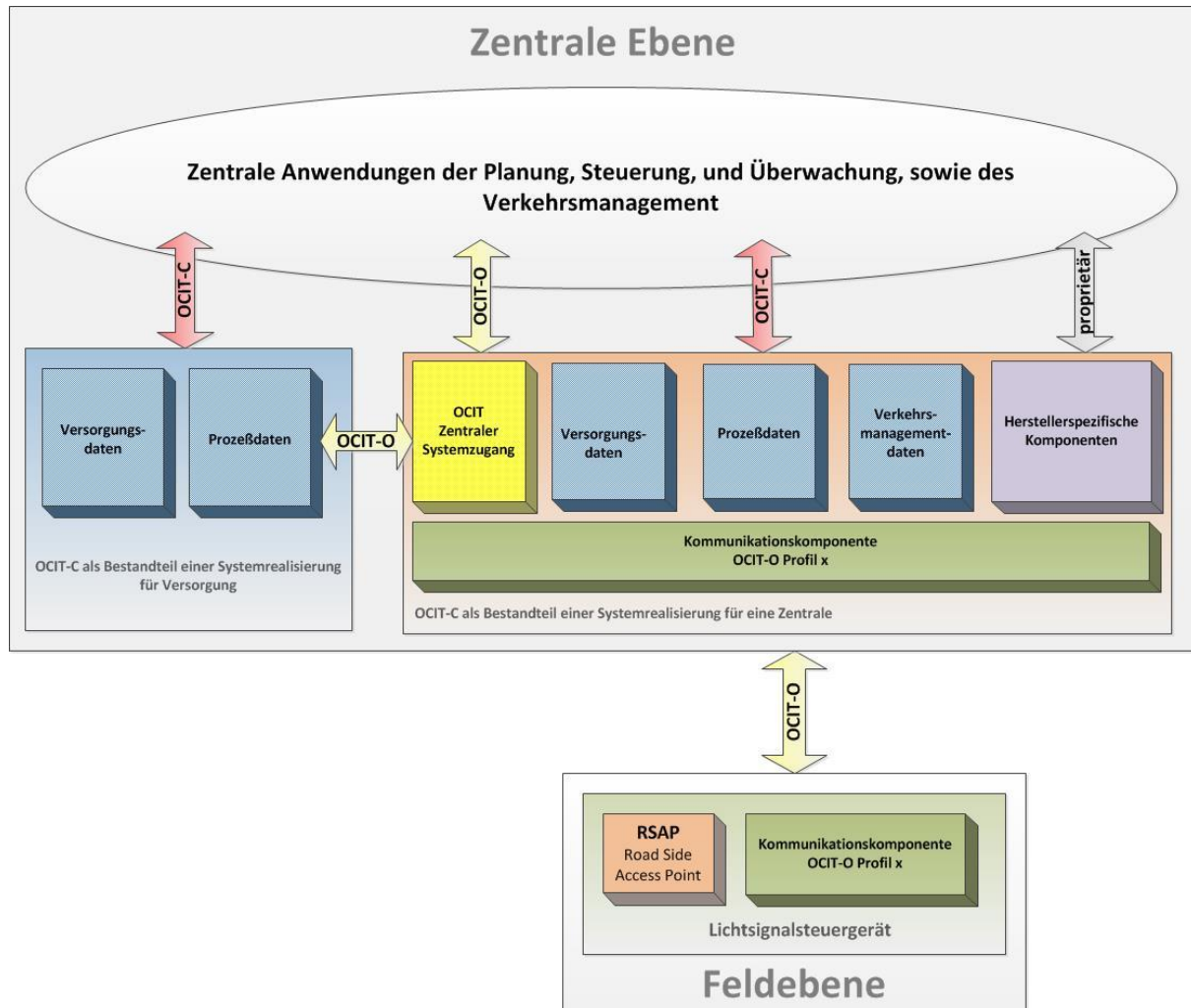

Figure 1 Arrangement of the OCIT-C interface in the level schema of a traffic signal control system with OCIT interfaces

2 Data model

The data source is responsible for the data defined in the *intersection_config_data.xsd* data model. It is assumed that no data will be interpreted, controlled or modified for transport. The intuitiveness of the data is also not checked at any point within the data model.

In addition to the TSS basic supply, the data model contains a framework for supplying traffic-procedures as well as a checksum list, which the supply program is able to use to check the affected parts of the basic supply using checksums.

The first part of this document describes the structure of the basic supply. It should be noticed here in particular that not all elements of this basic supply can also be supplied

remotely. The second part describes the framework and the checksums of the data. The structure is basically used to facilitate the following activities:

1. The representation of the traffic, device and safety technology as a basis for planning.
2. The user supply of traffic signal controllers with OCIT-O interfaces through appropriate central devices or supply tools.
3. The return documentation of a supply from the traffic signal controller. In the event of such a reconstruction, it may be the case that not all the data that was created during the planning stage are reconstructed. This concerns all data, which had not been transferred to the traffic signal controller and therefore are not available.
4. The exchanging of data between planning tools. In the format described here, the purely planning-related data are only standardised to an extremely small extent.

The OCIT-C interface described here for TSS supply data is designed for tasks 1 and 4. Cases 2 and 3 are not included here and will be handled by the supply data server.

2.1 Structure of the file intersection_config_data.xsd

The structure of the file can be summarised as follows:

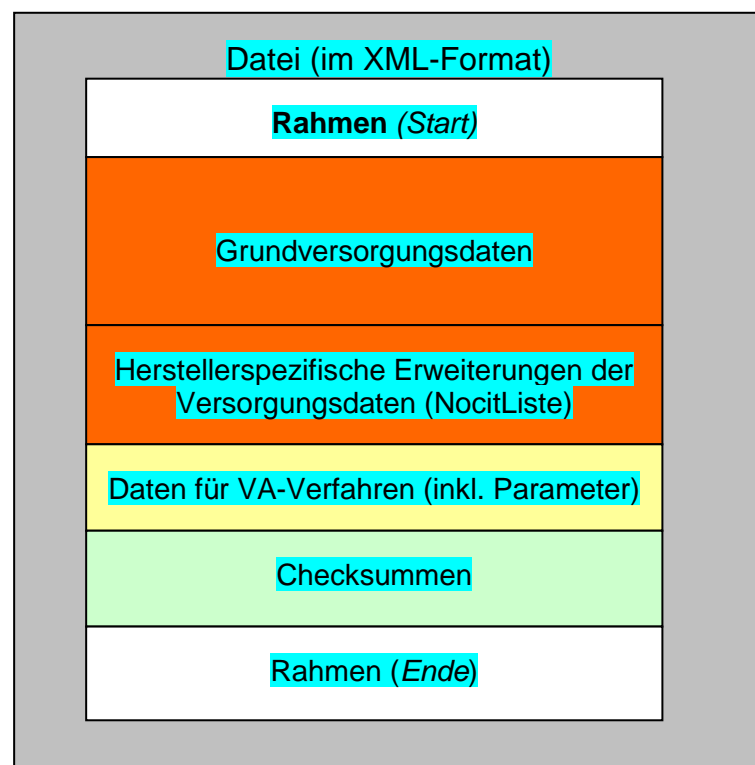

Figure 2: Structure of the supply data

2.2 Distribution of the planning and supply data

All of the supply data to be transferred is distributed into various blocks. After consultation with the participating work groups, a partial supply must always relate to one of the blocks.

The following table shows the required structuring of the data in blocks.

In OCIT-C LSA Versorgungsdaten standardisierte Versorgungsdaten, herstellerübergreifend versorgbar und auslesbar Anwenderversorgung				
Verkehrstechnik			Topologie	
Verkehrs-technische Grunddaten / Festzeit	Daten mit Netzbezug	VA-Steuerverfahren	VA-Parameter	MAP
.....
.....
.....
OCIT-O Checksummen Server ⁴⁾	OCIT-O Checksummen Server ⁴⁾	OCIT-O Checksummen Server ⁴⁾	OCIT-O Checksummen Server ⁴⁾	OCIT-O Checksummen Server ⁴⁾
OCIT-C Version ¹⁾	OCIT-C Version ¹⁾	OCIT-C Version ¹⁾	OCIT-C Version ¹⁾	OCIT-C Version ¹⁾
OCIT-C Checksumme ¹⁾	OCIT-C Checksumme ¹⁾	OCIT-C Checksumme ¹⁾	OCIT-C Checksumme ¹⁾	OCIT-C Checksumme ¹⁾
Auftraggeber ¹⁾	Auftraggeber ¹⁾	Auftraggeber ¹⁾	Auftraggeber ¹⁾	Auftraggeber ¹⁾
OCIT-O Checksumme Gerät ³⁾	OCIT-O Checksumme Gerät ³⁾	OCIT-O Checksummen Gerät ³⁾	OCIT-O Checksumme Gerät ³⁾	OCIT-O Checksumme Gerät ³⁾
Build-Nr. ³⁾	Build-Nr. ³⁾	Build-Nr. ³⁾	Build-Nr. ³⁾	Build-Nr. ³⁾
Session-ID ⁵⁾	Session-ID ⁵⁾	Session-ID ⁵⁾	Session-ID ⁵⁾	Session-ID ⁵⁾
Zeitstempel Übertragung beendet ³⁾	Zeitstempel Übertragung beendet ³⁾	Zeitstempel Übertragung beendet ³⁾	Zeitstempel Übertragung beendet ³⁾	Zeitstempel Übertragung beendet ³⁾
Zeitstempel Aktivierung ³⁾	Zeitstempel Aktivierung ³⁾	Zeitstempel Aktivierung ³⁾	Zeitstempel Aktivierung ³⁾	Zeitstempel Aktivierung ³⁾
Fully Qualified Domain Name ³⁾	Fully Qualified Domain Name ³⁾	Fully Qualified Domain Name ³⁾	Fully Qualified Domain Name ³⁾	Fully Qualified Domain Name ³⁾
OCIT-O Checksumme Gerät Gesamt ³⁾				
Build-Nr. Gesamt ³⁾				

In OCIT-C LSA Versorgungsdaten standardisierte Versorgungsdaten, herstellerübergreifend versorgbar und auslesbar Anwenderversorgung			
Verkehrstechnik			
Verkehrs-technische Grunddaten / Festzeit	Daten mit Netzbezug	VA-Steuerverfahren	VA-Parameter
.....
.....
.....
OCIT-O Checksumen Server ⁴⁾	OCIT-O Checksumen Server ⁴⁾	OCIT-O Checksumen Server ⁴⁾	OCIT-O Checksumen Server ⁴⁾
OCIT-C Version ¹⁾	OCIT-C Version ¹⁾	OCIT-C Version ¹⁾	OCIT-C Version ¹⁾
OCIT-C Checksumme ¹⁾	OCIT-C Checksumme ¹⁾	OCIT-C Checksumme ¹⁾	OCIT-C Checksumme ¹⁾
Auftraggeber ¹⁾	Auftraggeber ¹⁾	Auftraggeber ¹⁾	Auftraggeber ¹⁾
OCIT-O Checksumme Gerät ³⁾	OCIT-O Checksumme Gerät ³⁾	OCIT-O Checksumen Gerät ³⁾	OCIT-O Checksumme Gerät ³⁾
Build-Nr. ³⁾	Build-Nr. ³⁾	Build-Nr. ³⁾	Build-Nr. ³⁾
Session-ID ⁵⁾	Session-ID ⁵⁾	Session-ID ⁵⁾	Session-ID ⁵⁾
Zeitstempel Übertragung beendet ³⁾	Zeitstempel Übertragung beendet ³⁾	Zeitstempel Übertragung beendet ³⁾	Zeitstempel Übertragung beendet ³⁾
Zeitstempel Aktivierung ³⁾	Zeitstempel Aktivierung ³⁾	Zeitstempel Aktivierung ³⁾	Zeitstempel Aktivierung ³⁾
Fully Qualified Domain Name ³⁾	Fully Qualified Domain Name ³⁾	Fully Qualified Domain Name ³⁾	Fully Qualified Domain Name ³⁾
OCIT-O Checksum. Gerät Gesamt ³⁾			
Build-Nr. Gesamt ³⁾			

Figure 3: Schema of the supply data blocks and version data of the user supply

- 1) Generated by the TEWS and saved in the traffic signal controller.
- 2) Generated by the manufacturer's tool and saved in the traffic signal controller.
- 3) Generated in the traffic signal controller and saved.
- 4) Generated in the VD server and saved.
- 5) Generated in the VD server and saved in the traffic signal controller

Outlined in blue: Version data of OCIT-C VD server that are managed in OCIT-C components.

In OCIT-C LSA Versorgungsdaten teilweise stand. Versorgungsdaten, nur proprietär versorgbar und auslesbar Herstellerversorgung			
Gerätetechnik		Sicherheitstechnik	
OCIT-C Versorgungsdaten	Proprietäre Daten	OCIT-C Sicherheitsdaten	Proprietäre Daten
.....
.....
.....
Hersteller-Version ²⁾		Hersteller-Version ²⁾	
Hersteller-Checksumme ²⁾		Hersteller-Checksumme ²⁾	
Hersteller-Checksumme Gerät ³⁾		Hersteller-Checksumme Gerät ³⁾	
Build-Nr. ³⁾		Build-Nr. ³⁾	
OCIT-O Checksum. Gerät Gesamt ³⁾			
Build-Nr. Gesamt ³⁾			

Figure 4: Schema of the supply data blocks and version data of the manufacturer supply

- 2) Generated by the manufacturer's tool and saved in the traffic signal controller.
 3) Generated in the traffic signal controller and saved.

Anwendersversorgung		Herstellerversorgung	
Verkehrstechnik	Topologie	Gerätetechnik	Sicherheitstechnik
OCIT-O Checksum. Gerät Gesamt ³⁾			
Build-Nr. Gesamt ³⁾			

Figure 5: Schema of the version data

Outlined in black: Version data that are managed in the traffic signal controller (OCIT-O object version)

There is a complete controller supply from the data of the user supply with:

- Basic traffic-related data / fixed time
These are all data which directly correspond to the hardware of the traffic signal controller.
- Data for traffic-actuated control
These are data and parameters for the TA control procedure.
- Data with network reference
These are data from the OCIT central system, such as the 12 month automatic routine.
- Manufacturer data.
These are non-standardised data (also referred to as NOCIT = No OCIT data). Not all of these data can be supplied by the user.

The distribution above is also the basis of the version concept. The following requirements apply to this:

- A full supply will be distributed into six data blocks. It must be possible to individually version each individual block, the blocks must also be summarised by an overall version.
- Each change, even just a single datum within a block, leads to an immediate updating of the version.
- All tools involved with the creation and supply of data must use the same versioning principles. This makes it possible to carry out a simplified check by comparing the version numbers, if the version numbering is subject to generally applicable rules.
- Each tool which modifies the data of a data must be capable of documenting the complete data block. (Only applies for block TA with the restriction that each tool is responsible for its part of the block). This is not an obstacle, as the block TA in the event of multiple TA procedures present in the traffic signal controller (e.g. control procedure and local traffic model) are also strictly speaking divided into corresponding number of independent TA blocks). All pages of the documentation must hold the classification of the individual documents and version.
- Each central system must know which version is in operation in the devices within reach at all times.

3 Basic supply data for TSS

The data for the device supply and the standardised program supplies are saved together in a structure, which is depicted in red in chapter 2.1. The `<NocitListe>` is used to be able to save manufacturer data, all other entries are fully standardised. Strings must be coded in UTF-8.

3.1 Version information of the XML schemas

Version information about the XML schemas used are specified under the datum `<DateiVersion>`.

The three-digit version number of the document to which the file refers is entered into `<VersionDokument>`. In this, the first place is for changes to existing elements (not backwards compatible). The second place changes in the event of expansions to the schema and the third place shows editorial changes which do not constitute a schema change (e.g. notes).

The `<VersionsDatenstruktur>` contains the version of the schema file, to which the XML file relates. The version of the schema file is located in the "Version" attribute of the `<Schema>` element (header of the underlying XSD file).

The `<VersionBlockzuordnung>` contains the version of the XML file, in which the block assignment is specified. The version of the XML file is in the `<VersionBlockzuordnung>` datum. The block assignment is clarified in Chapter 4.4.

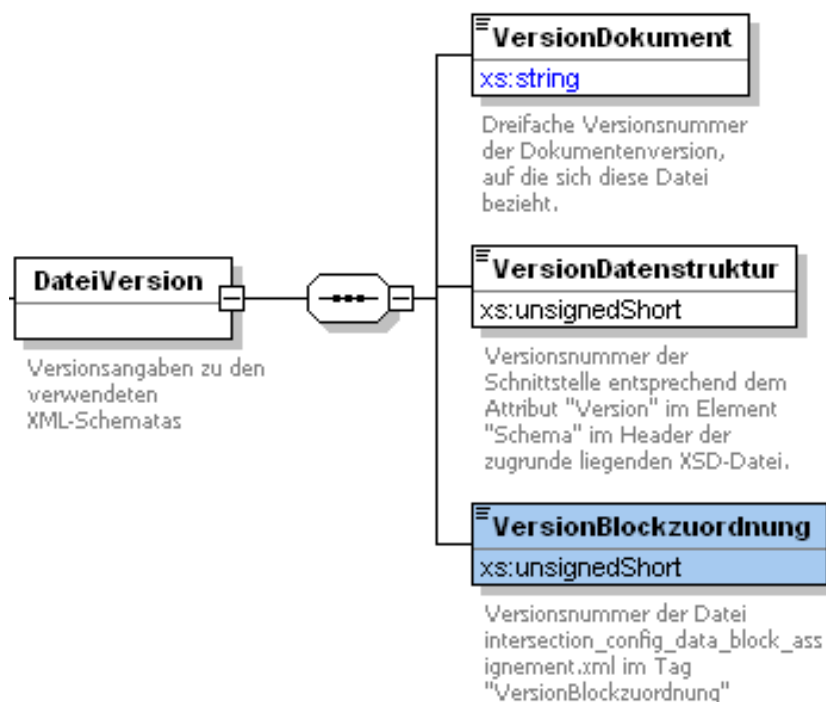

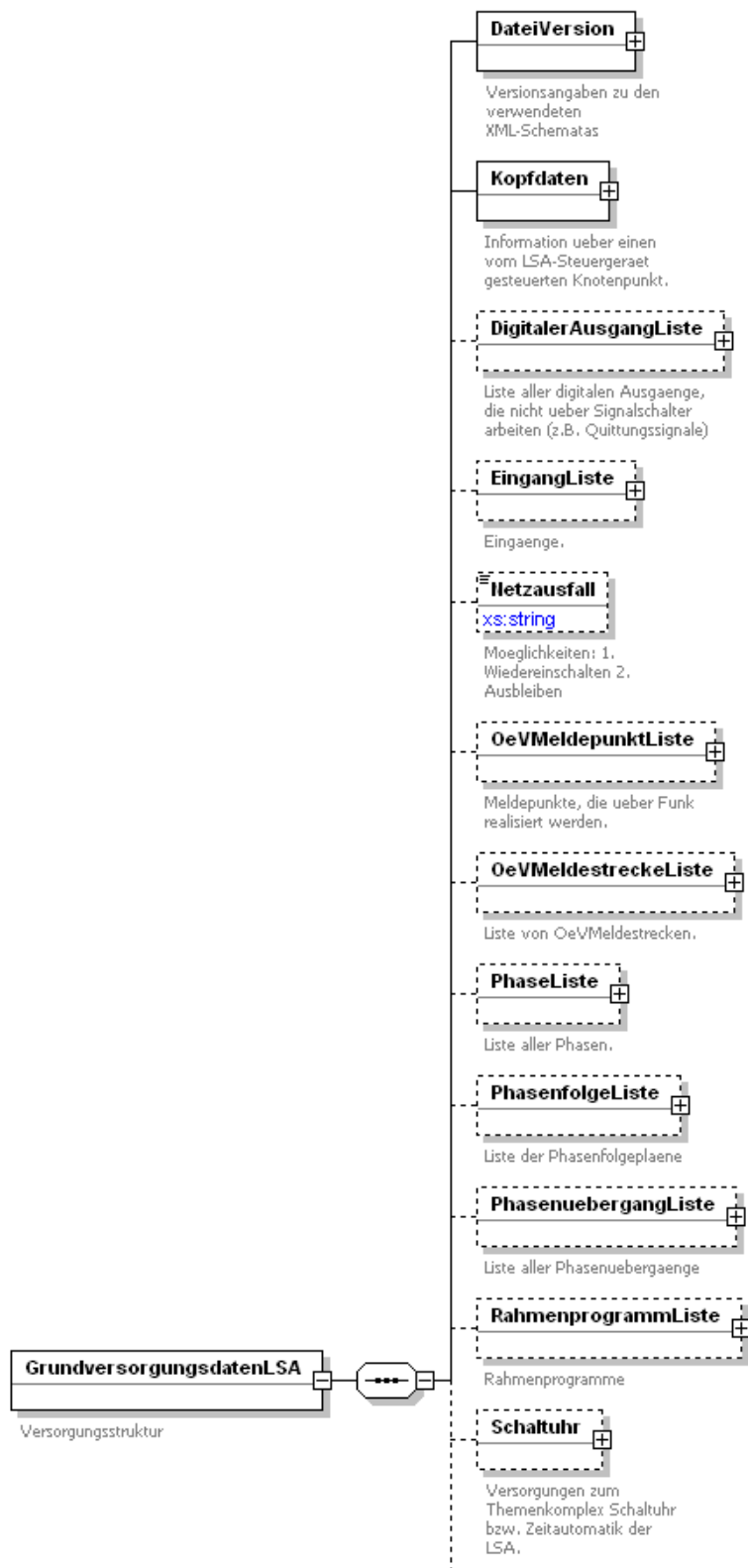



3.2 Header data

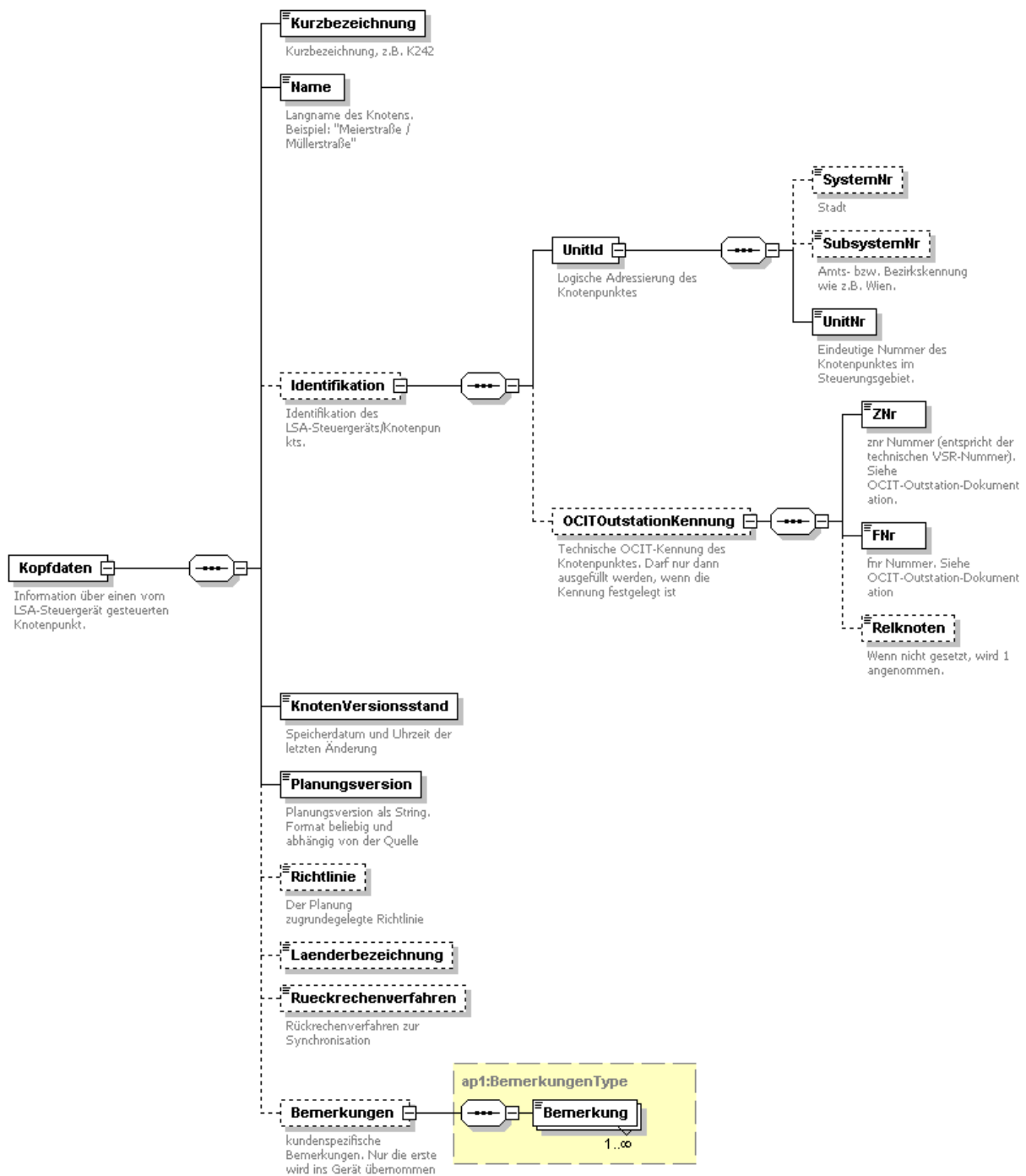

The header data include all the information describing the intersection itself:

- **Short name** – is the short name specified by the customer for the intersection, being at most 10 letters long. The short name is inside the file of the keys. During supply, identification is strictly required! The short name can, for example, be used in cross-intersection structures (which are not currently standardized). The short name can be used as a reference in the XML file.

It has the following restrictions:

- The short name may include:
 - Uppercase and lowercase letters, but not "umlauts" or the "ß" character
 - Numbers 0 through 9
 - Blanks
 - Special characters . , - + / _ = : () ? ! | # < >
- Leading or trailing blanks are not permitted.
- Two consecutive blanks are not permitted.
- The short name must begin with an alphabetic character.
- The following regular expression defines these restrictions exactly:

```
[A-Za-z]([ ]?[A-Za-z0-9\.,\|\+/_=:\(\)\!|\#&<.>])
```
- **Name** – the name of the intersection can be at most 250 characters long. Control characters (line breaks, tabulators, etc.) are not permitted.
- **Identification** – identifies the intersection. In this simple planning phase, this element can be left out for the time being if the UnitID is not yet set.
There are two different identifications in the OCIT world:
The OCIT outstations identification, consisting of "ZNr", "FNr" and "RelIntersection" depend on technology and can change during the life of the intersection. The identification must be present for each device connected via outstations. If the numbers are unknown, the entry will be left out.
The OCIT-C identification consists of a system and subsystem number as well as the actual UnitID. The system and subsystem number is needed for large systems on which the overall system is structured. In this case, the values must be entered
- The **IntersectionVersion** and the planning version are in regard to the tool that carried out the last change. Both pieces of data are not transferred to the controller.
- The **Guidelines** are a help text indicating the guidelines according to which planning took place. If none of the guidelines listed applies, the field is to be left out.
- The **"Laenderbezeichnung"** contains the country for which planning took place and therefore a direct reference to the necessary guidelines.
- The **"Rueckrechnungsverfahren"** is number code describing the process for determining the start of the circulation. The code is the same code used in OCIT Outstations. If the back calculation process is unknown, the field is to be left out.
 - 0 = None or unknown
 - 1 = Coordinate Universal Time (UTC)
 - 2 = 1.1. current year
 - 3 = 1980-1-1
 - 4 = 0:00 o'clock of the current day
- Optionally, **remarks** can be specified. However, only the first remark is transmitted during user supply of the controller. Regardless of how many remarks there are. Additional remarks are therefore only used for an exchange between planning tools

3.3 The OCITObjektHeader

Very many elements in the basic supply must be identified. For this reason, a basic structure has been created with which these objects "begin" and contain the identification. This standard header is described here:



The "**BezeichnungKurz**" is the short designation of the object. It is known to the user and can change with time. This designation is used as a reference in the XML structure. This makes the standardized data structure significantly easier to understand. The "BezeichnungKurz" can only be used once in a single list. Upper and lower case is distinguished between. The object "a1" is therefore a different object from the object "A1".

The "**BezeichnungLang**" is the full designation of the object, but it is no longer used and therefore can be applied freely. This name must also be unique within a single list. It is not compulsory for the "DesignationLong" to be set.

The "**OCITOutstationNr**" (without the 0) is the number identifying the object in communication via OCIT Outstations. Normally, it is necessary to set this. There are only the following exceptions:

- During the first planning phase, the technical connection of the intersection to the OCIT control center is unknown. In this phase, the OCIT number has not yet been set.
- Some objects are not addressed with the OCITObjektHeader in the OCIT Outstations protocol. For these objects, the number is not necessary and can be left out.
- Traffic signal controllers that are not connected via OCIT Outstations do not need the number.

The number may also be set for the exceptions indicated. In this case, the number must also be retained by tools for which it means nothing.

The "**OrganisationsNr**" (without the 0) is a number assigned by the user. It must be unique within the list. Tools that do not use any OrganisationsNr must retain an already-supplied OrganisationsNo. The OrganisationsNr is optional. Tools that need such a number may have to add it.

The "**LetzteAenderung**" is optional and consists of a user who carried out the last change as well as a timestamp for the time at which the last change was carried out. Entry is optional. Tools that do not have control over this entry must delete this entry upon a change to the object! (Of course, the entry must be retained if no change has been made to the object.)

The "**Bemerkungen**" field contains a list of remarks created for this object by the customer and must be fully editable. Tools that have no control over this field must fully retain its contents. It is not permitted for individual tools use entries in the remarks in order to save additional parameters that are not standardized¹.

The "**Objektlage**" is used to save the coordinates of the object's position. This information is, however, not transmitted to the controller. To make it possible for engineers at different locations to correctly interpret the coordinates, the coordinate system used must be indicated.

¹ Such parameters can be filed as Nocit objects.

3.4 Standardized objects

3.4.1 Digital outputs

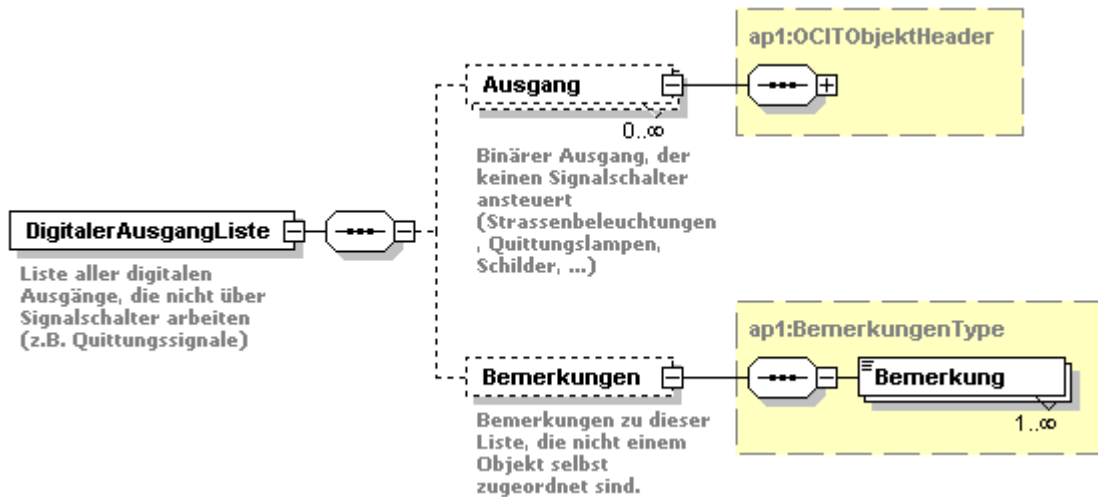

OCIT Outstations manage digital outputs in the number range from 1 to 255. The number range (in contrast to an earlier version) depends on the number range of the signal groups.

3.4.2 Inputs

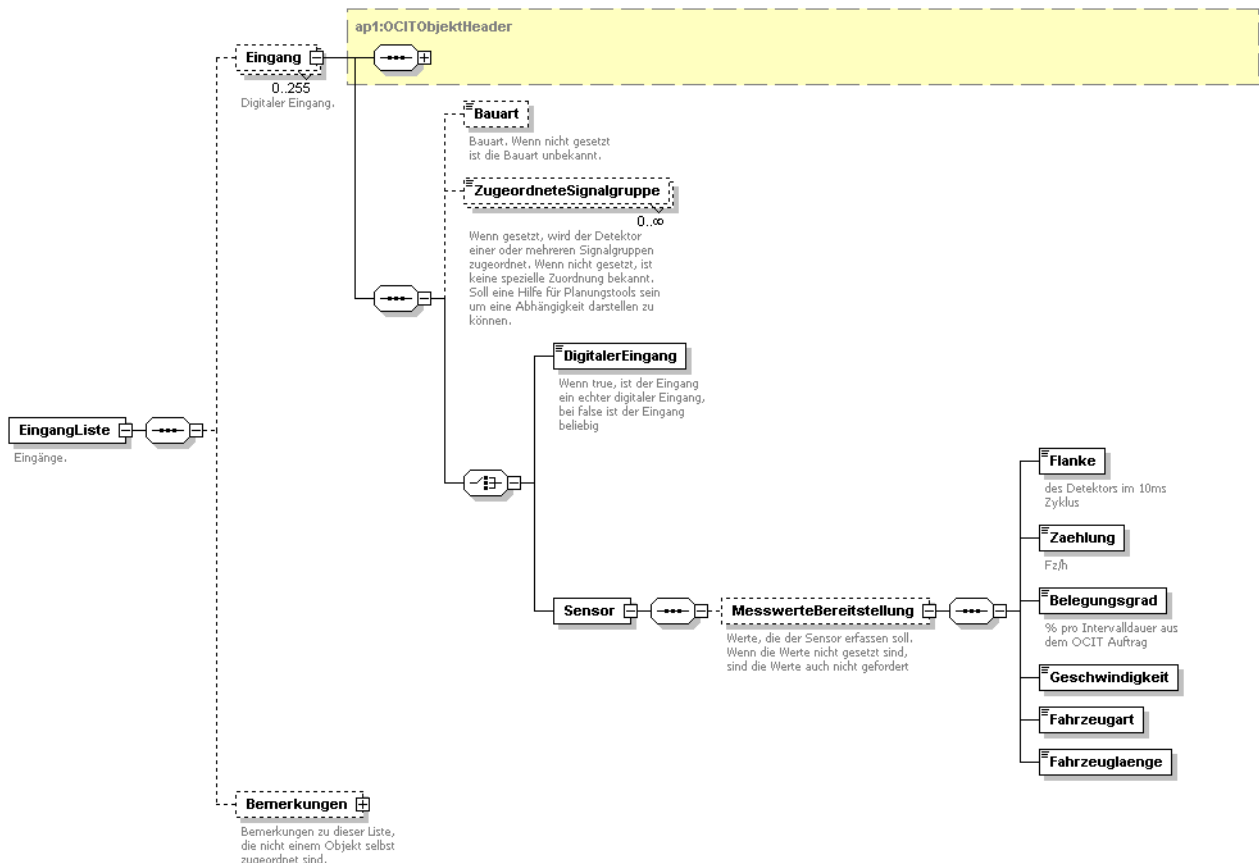

All inputs are supplied in the input list. This applies both to sensors as well as any digital inputs not used as sensors.

The **type** of the input indicates the kind of input. The following types are standardised:

- Button
- Loop
- Double loop
- Contact
- Radio
- Infrared
- Video
- Laser
- Radar
- Error input
- Other

If the type is unknown, the entry will be left out. If the type is known but does not belong to the normal elements of the list, "Other" will be indicated.

For inputs used as sensors, there may be additional information entered:

- What values does a sensor provide? This does not mean that the sensor is constantly sending out values because they must first be requested. It only means that these values can be requested. The individual fields under the "**MesswerteBereitstellung**" are logical values that can be either "true" or "false".
- **Assigned signal group**: To what signal groups is the detector assigned? If a detector is assigned to a signal group, this means that the traffic flow registered by the detector is managed with the signal group. The opposite conclusion should not be drawn: If there is no assignment, this does not mean that the detector is not assigned to any signal group.

Remarks relating to the list as a whole can be entered in the field "**Bemerkungen**".

3.4.3 Power outage



Moeglichkeiten: 1.
Wiedereinschalten 2.
Ausbleiben

This piece of information is used to define what behavior the controller should exhibit after a power outage. There are only two options:

- 1.) Switch back on
- 2.) Remain off

3.4.4 PT reporting points

PT reporting points are triggered by a radio telegram or a message and can be used within a PT reporting section. The PT reporting point indicates that triggering PT vehicle is a certain distance away from the stop line in a certain direction at this time. The PT reporting point is referenced by the BezeichnungKurz within the PT reporting section.

The PT reporting point list ensures that the PT reporting points can be defined even without knowing the PT reporting point section

The PT reporting point can be triggered at a sensor (<Eingang>). In this case, the PT reporting point is entered both into the input list as well as the reporting point list.

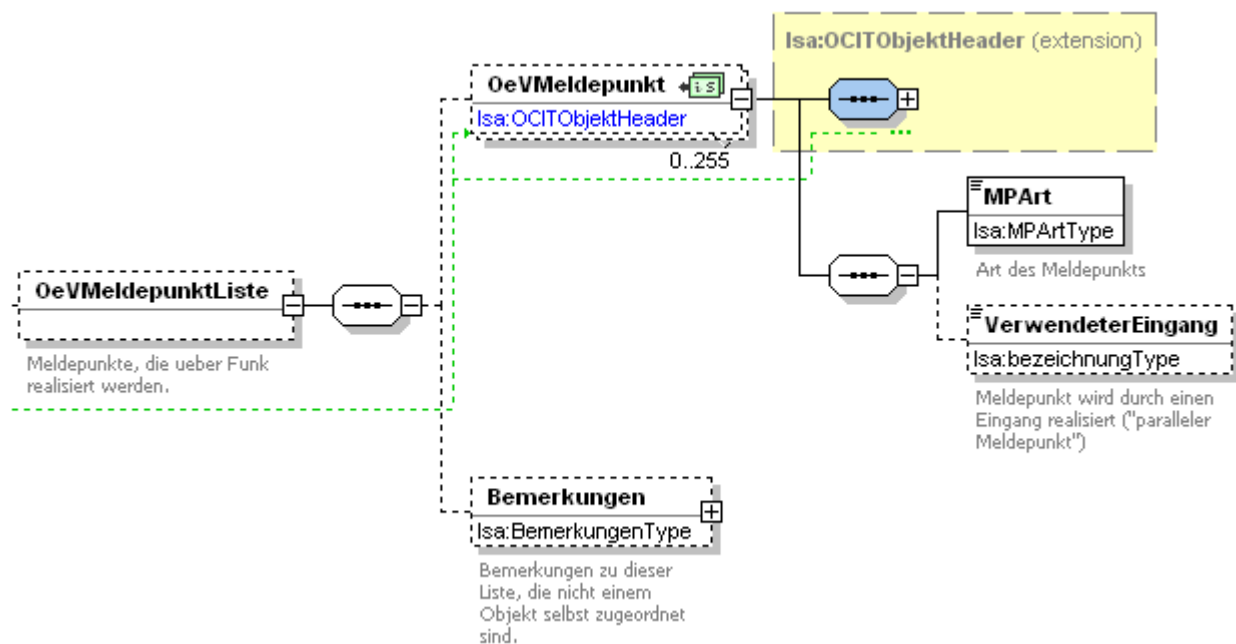

The reporting point type is defined in "**RPtrype**". The following values are approved:

- Parallelimpulse
- Serial
- ParallelGap
- SerialAnTA
- Other
- NotAvailable

3.4.5 PT reporting sections

Every PT reporting section consists of a series of reporting points relating to one stop line. The distance from the stop line is positive if the point is past the stop line (always as seen in the direction of travel) and negative if the point is behind the stop line.

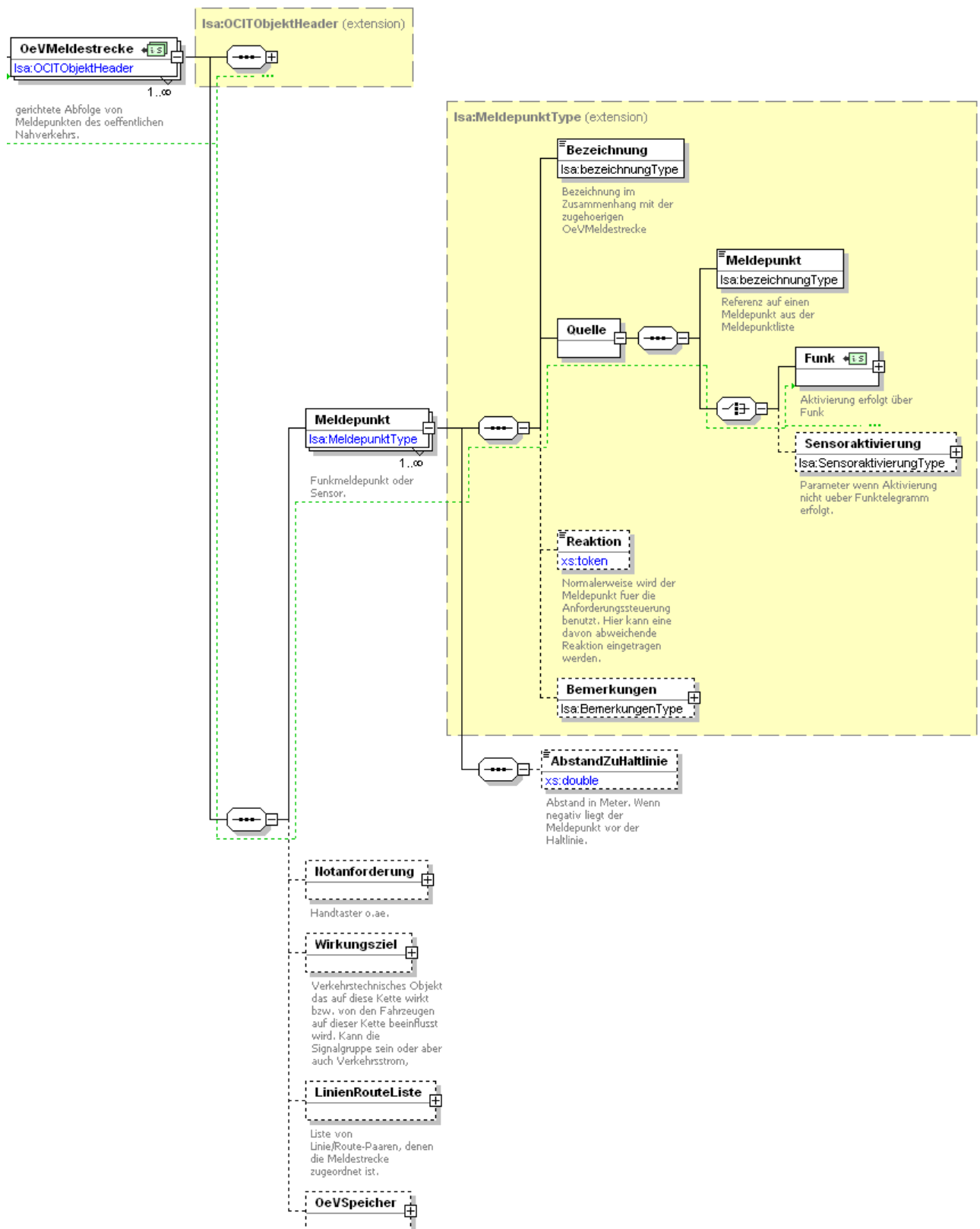

Statements can be made in the "Reaction" field about the effects brought about by the reporting point in the traffic-actuated controller. If the field is missing, then this entails the following "default" behavior. The reporting point with the greatest distance from the stop line is the log-off point, all other reporting points are the log-on points, counted in order of decreasing distance from the log-off point. If a structure that deviates from this is described, then the "Reaction" field will be used.

The values that the field can take on are not prescribed by the OCIT standard but rather are determined according to the relevant control process. The "Function" field in the "PTMemory" data structure plays a similar role.

3.4.5.1 Data model

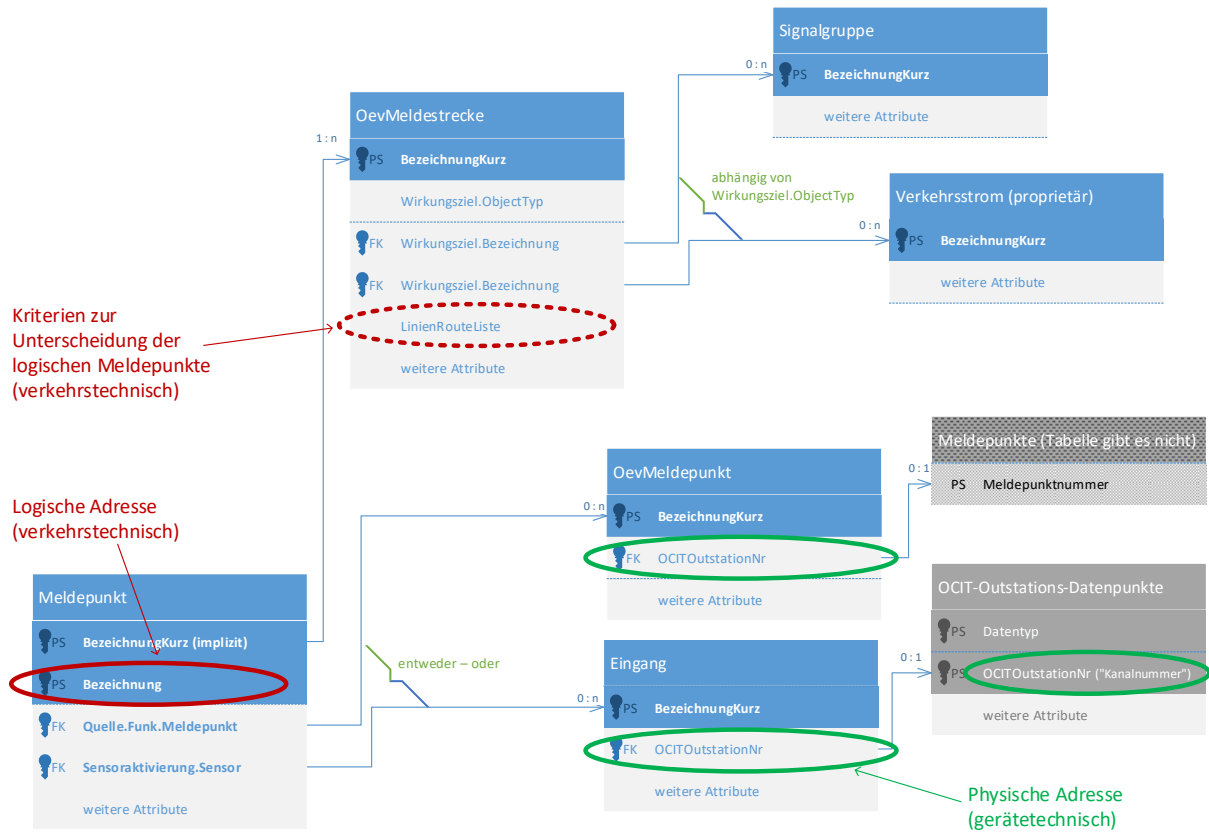

The diagram shows the data model for reporting points and reporting sections:

Reporting section

- Each reporting section consists of 1 to n reporting points.
- The reporting section is uniquely addressed via the "BezeichnungKurz" field (primary key) in the "PTReportingSection" table.
- Every reporting section can be linked to either a signal group or a traffic flow or to an object of another kind, managed by the "Wirkungsziel.ObjectTyp" field (see section 3.4.5.5).
- Reporting sections can be restricted to certain vehicles. The "LinienRouteListe" list can be used here (see section 3.4.5.6).

Reporting point

- The reporting points are implemented in the XML structure as branches "Reporting-Point" of a reporting section "PTReportingSection".
- The reporting point is therefore uniquely formed using a primary key composed of the "BezeichnungKurz" field of the "PTReportingSection" and the "Designation" field from the "ReportingPoint" table.
- This kind of addressing is logical addressing. Every reporting point can refer to a physical reporting point, either of type "PTReportingPoint" (radio telegram) or of type "Input" (sensor, see sections 3.4.5.2 and 3.4.5.3).

- There you can find the physical address of the reporting point under "OCITOutstationsNr".

Some conclusions

- The same physical reporting point can arise in multiple logical reporting points and therefore in multiple reporting sections.
- There are not specifications about assigning names. Particularly, the physical and logical reporting points do not have to have the same name.

3.4.5.2 Reporting points triggered by radio

Reporting points triggered by radio telegrams contain the reporting point number sent in the radio telegram.

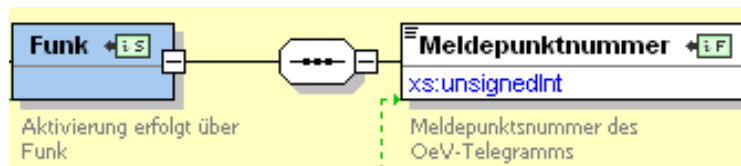

3.4.5.3 Reporting points triggered by sensors

Individual reporting points can be triggered by sensors instead of radio telegrams. In addition to the sensor, parameters can be indicated concerning activation of the sensor. It is possible to have a "steigendeFlanke" or "fallendeFlanke" as an activation type; the activation and de-bouncing period is indicated in seconds.

The values of the seconds can also include decimal places. The exactness of the value to be used is determined by the manufacturer of the traffic signal controller.

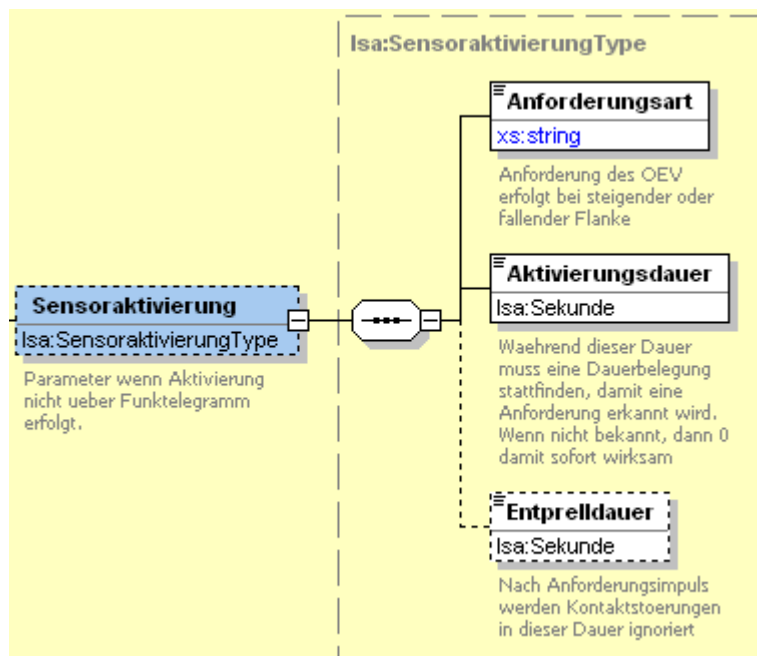

3.4.5.4 Emergency request

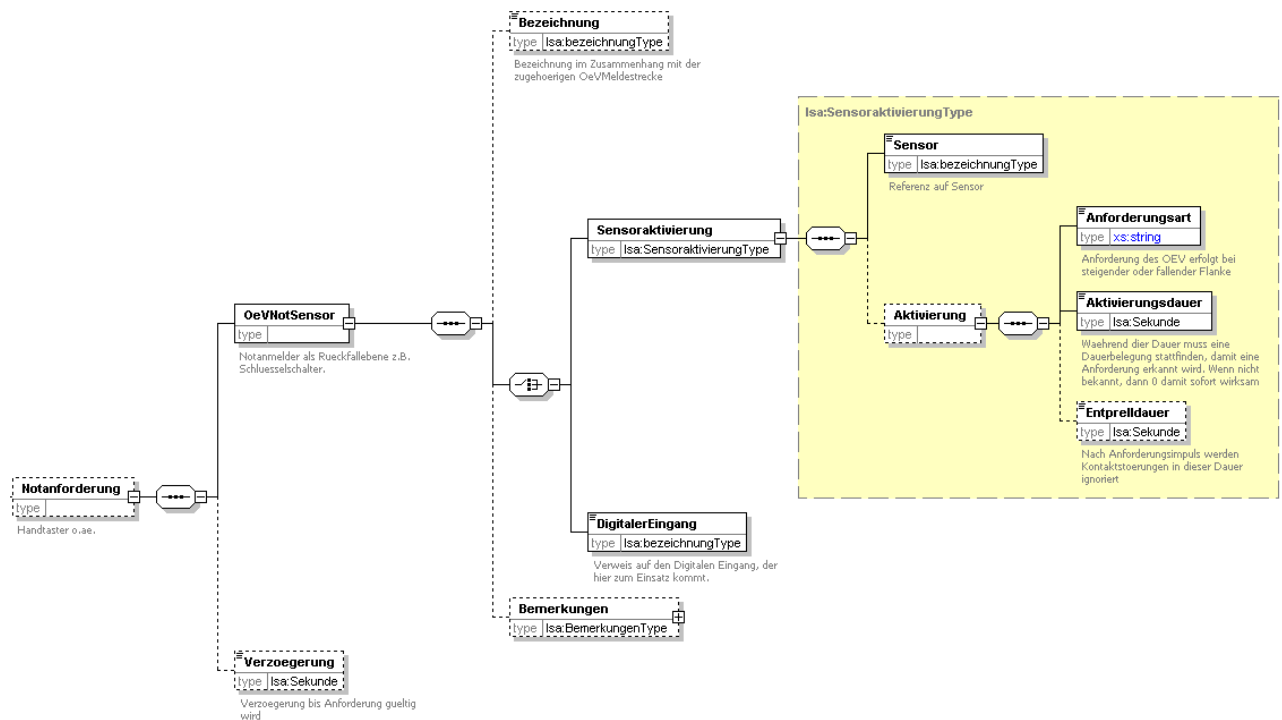

The emergency request is a special sensor—e.g. a button with which the reporting section can be requested independently of the other reporting points. The emergency request is, in any case, a sensor or another digital input.

If there is no emergency request, the entry will be left out.

3.4.5.5 Target effect

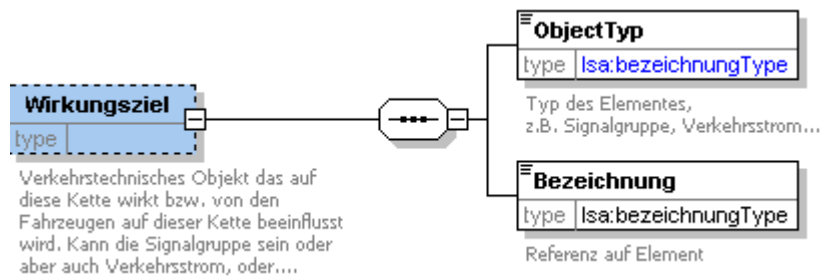

The target effect indicates the traffic-related object to which the PT reporting section refers. In most cases, this is a signal group, but it can be a traffic flow, a stage or a stage transition. If the target effect is unknown, it will be left out.

3.4.5.6 Line/route list

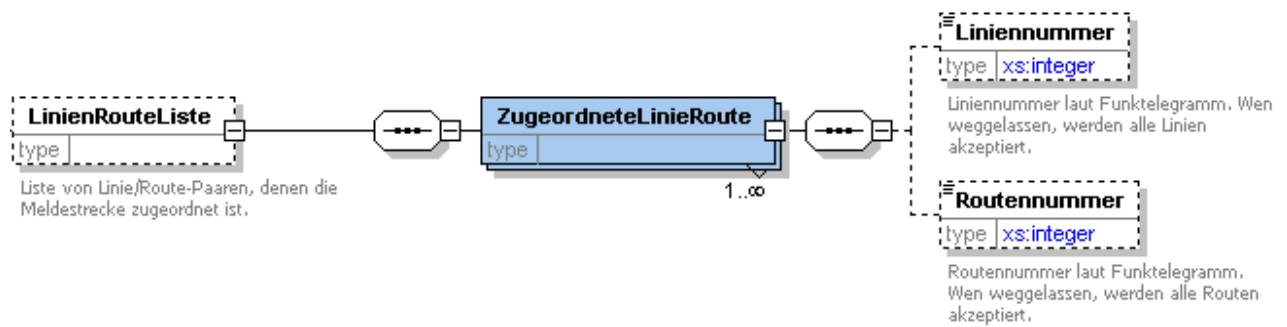

The line/route list is a filter regarding only radio telegrams. In addition to the reporting point number, it also includes a line and route ID.

If a line/route list is set, the entries only apply if at least one "ZugeordneteLinieRoute" is fulfilled. An **ZugeordneteLinieRoute** is either an exact pair of numbers here or an element covering all the lines of a route / all the routes of a line. For all lines of a route, the line entry will be left out; for all routes of a line, the route entry will be left out.

3.4.5.7 PT memory

The PT memory is an area that is only important for PT modules similar to PT memory. It contains additional data necessary for the configuration of this PT memory. The values declared here are not necessary for the basic description of the reporting area.

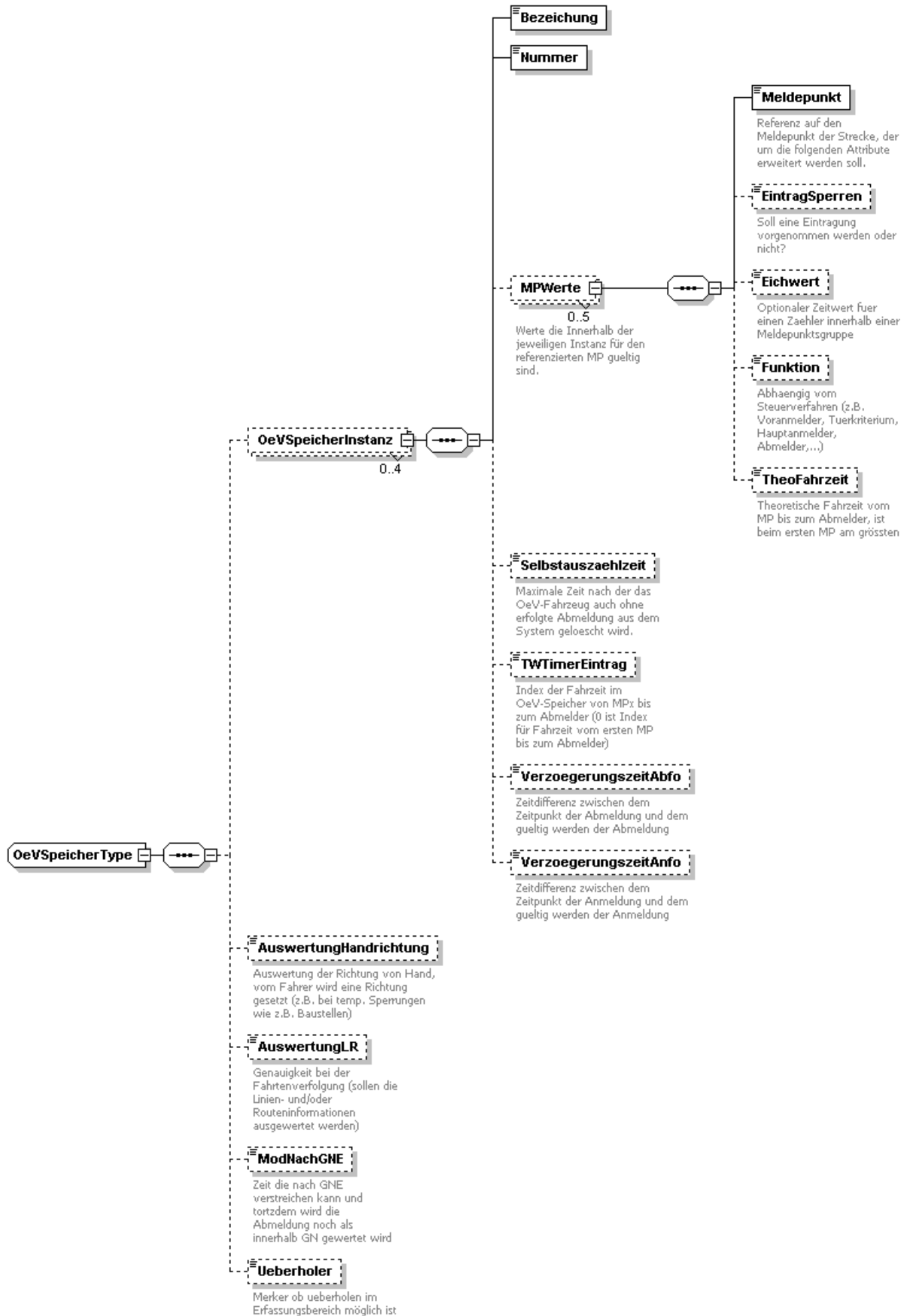

3.4.6 Stage

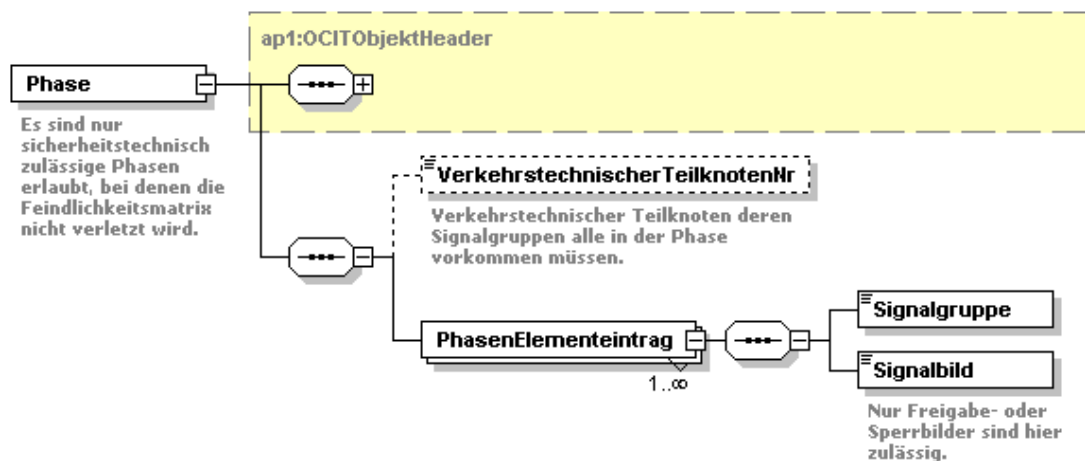

Stages are symbolized by the signal patterns of the signal groups from which the traffic conditions can be derived. The stage list is used only for exchange between planning tools and is not transmitted to the controller.

Two types of stages can be depicted: The standard green and red patterns are used for the classic traffic-related stages. For signal groups having more than one signal pattern for the same conditions—e.g. either "dunkel" or "grün" for "go"—there is a stage with the signal group "off" and another stage with the signal group "grün" for the same signal group. The hexadecimal codes as per OCIT-O are to be entered for the signal code (see signal group):

A traffic-engineering partial intersection can be entered. Its existence is depends on traffic.

Only stages not violating the conflicts matrix can be supplied. Traffic-related processes working with "Pseudophasen" for which, for example, all signal groups are entered as "frei" do not save any standardized pseudo-stages. Instead, it is permitted to do without a start or target stage during stage transitions if a pseudo-stage should be established here.

3.4.7 Stage sequence

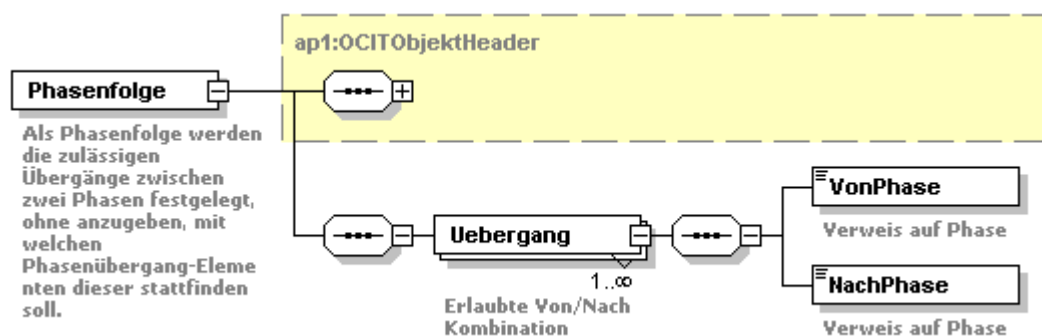

A stage sequence consists of a collection of all permitted from-stage / to-stage combinations. No specification is made about the stage transitions with which this switch between the stages should take place. The stage sequence list is used only for exchange between planning tools and is not transmitted to the controller.

3.4.8 Stage transition

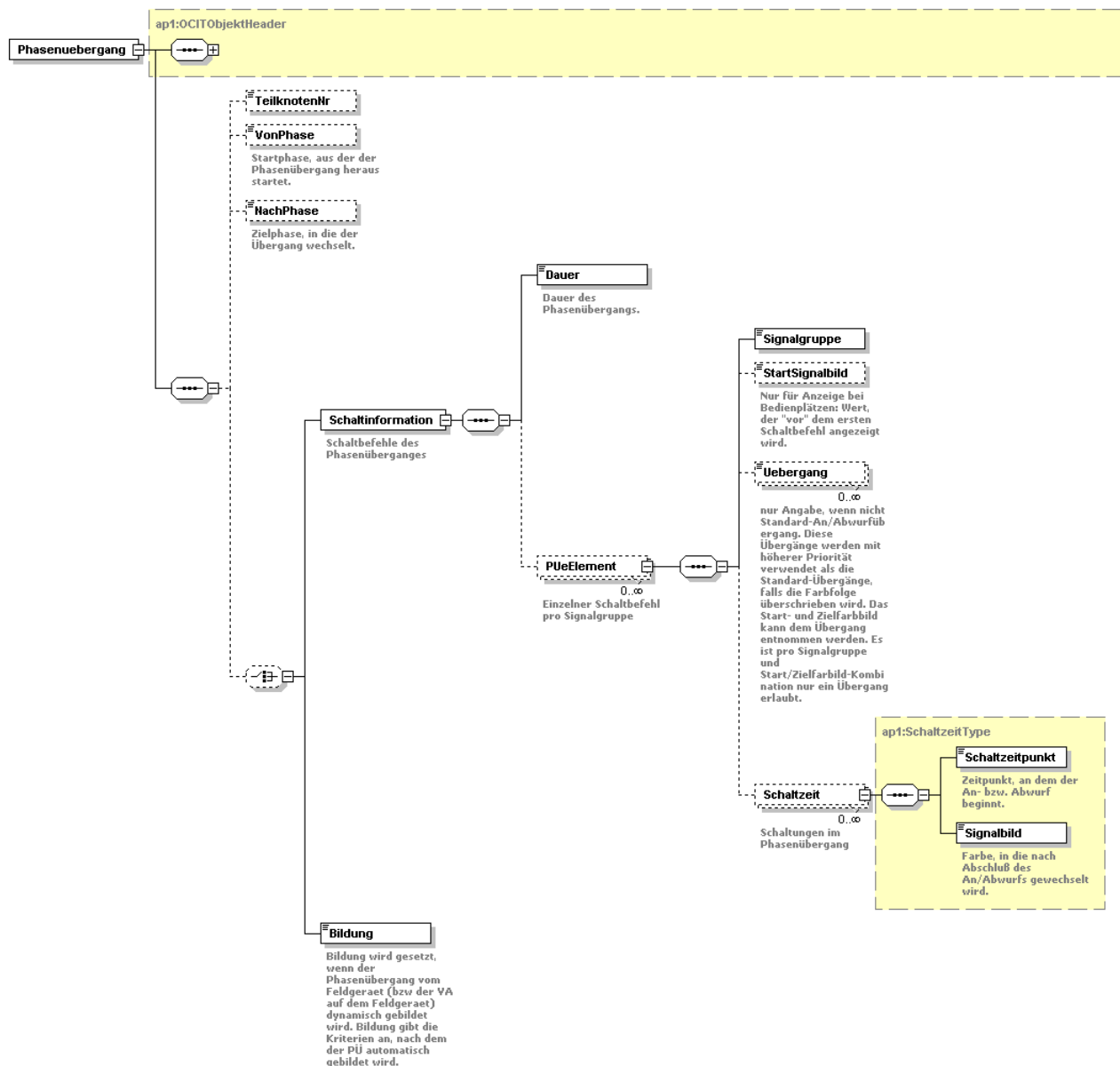

During the stage transmission, it is to be determined how switching can occur from a certain stage into another stage. The stage transition list is used only for exchange between planning tools and is not transmitted to the controller.

"VonPhase" indicates from which stage switching takes place, and "NachPhase" indicates to which stage switching takes place. Some traffic-related process use stage transitions for which no valid start or target stage is known. Even these stage transitions can be standardised, you just need not enter anything for the "VonPhase" or "NachPhase".

There is the option of creating empty stage transitions for which there is no additional information. In this case, it is the task of the traffic-related process to carry out the stage transition. The contents of such a stage transition, of course, cannot be displayed by other tools.

Stage transitions can, in some cases, be put together automatically by a traffic-related process. For this we have the cases "ZZMindestgruen", "ZZOhneMindestgruen" and "VAspezifisch".

The "Schaltinformation" is to be filled for fixed stage transitions. It includes the full duration of the stage transition,

The "Dauer" of stage transition is indicated in seconds. All "Schaltzeitpunkte" must be equal to or less than the duration.

The switching times are indicated for each signal group. Signal groups not involved in switching can nevertheless be entered (without switching time) in order to fulfill the partial intersection condition.

- The StartSignalBild is only used for illustrative purposes. In this case, the StartSignalbild is displayed in the graphical editor before the first switchover. If the StartSignalbild is missing, the associated color is removed from the corresponding entry of the start stage. If both entries are missing, the display of the graphical editor is undefined.
- Transition entries are only necessary if switching between the signal patterns should not take place with the default An- and Abwurf. In this case, reference is to be made to the desired transition. A transition between two green or red states is not permitted.
- For the switching time, the start of switchover and the desired target color are to be indicated. If a special transition entry between the current and target color is missing, the standard An- and Abwurf will be used.
Example: In a stage transition, switching is to take place from "Grün" to "Gelb" at time 2s and from "Gelb" to "Rot" at time 5s. The default Abwurf is 3s yellow. "2" is entered as the switching time and "Rot" for the signal pattern.
It is possible that at time "Dauer" (see above) not all changes initiated have already finished.
- There is the option to enter more than one switching time per signal group. The number of the permitted entries depends on the traffic signal controller. If switching times are indicated which follow each other so closely that the switchover has not yet finished, then the behavior of the traffic signal controller is not standardized and depends on the type of traffic signal controller.

3.4.9 Framework program

A framework program is a framework list assigned to one or more signal programs. Framework programs are generally used with coordinated traffic-actuated controllers. Supplying frame plans, however, is only used for the exchange between planning tools because the frame plans are not transmitted to the controller in a standardized way.

Frames are standardized time intervals within a signal program that can be applied to various traffic-related objects. These are traffic flows, stages, signal groups and it is furthermore possible to define additional frames without further reference. They will be identified by the beginning and end of the interval or can be continuously on/continuously off.

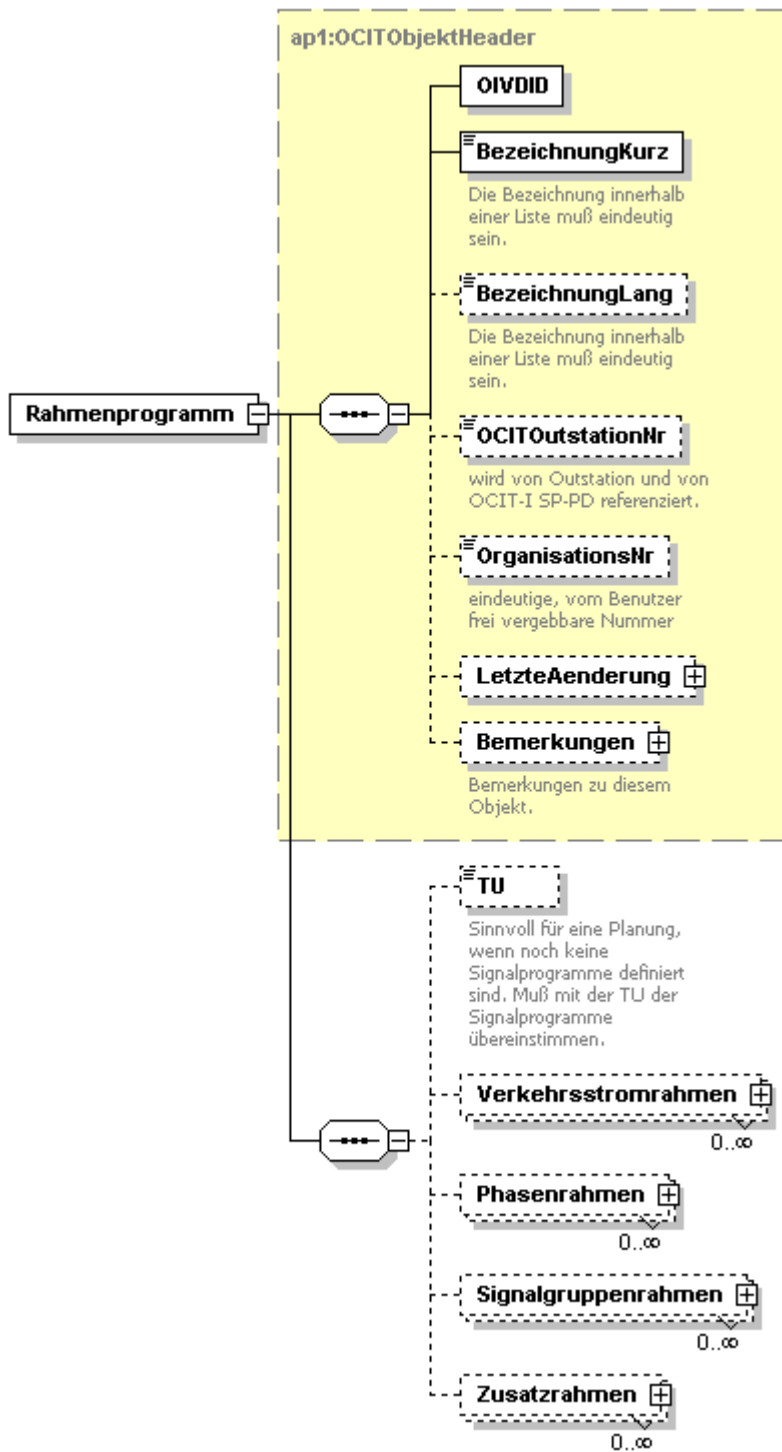

3.4.9.1 Stage frame plan

Within the stage frame plan it is also possible to indicate different frame intervals for IT and PT.

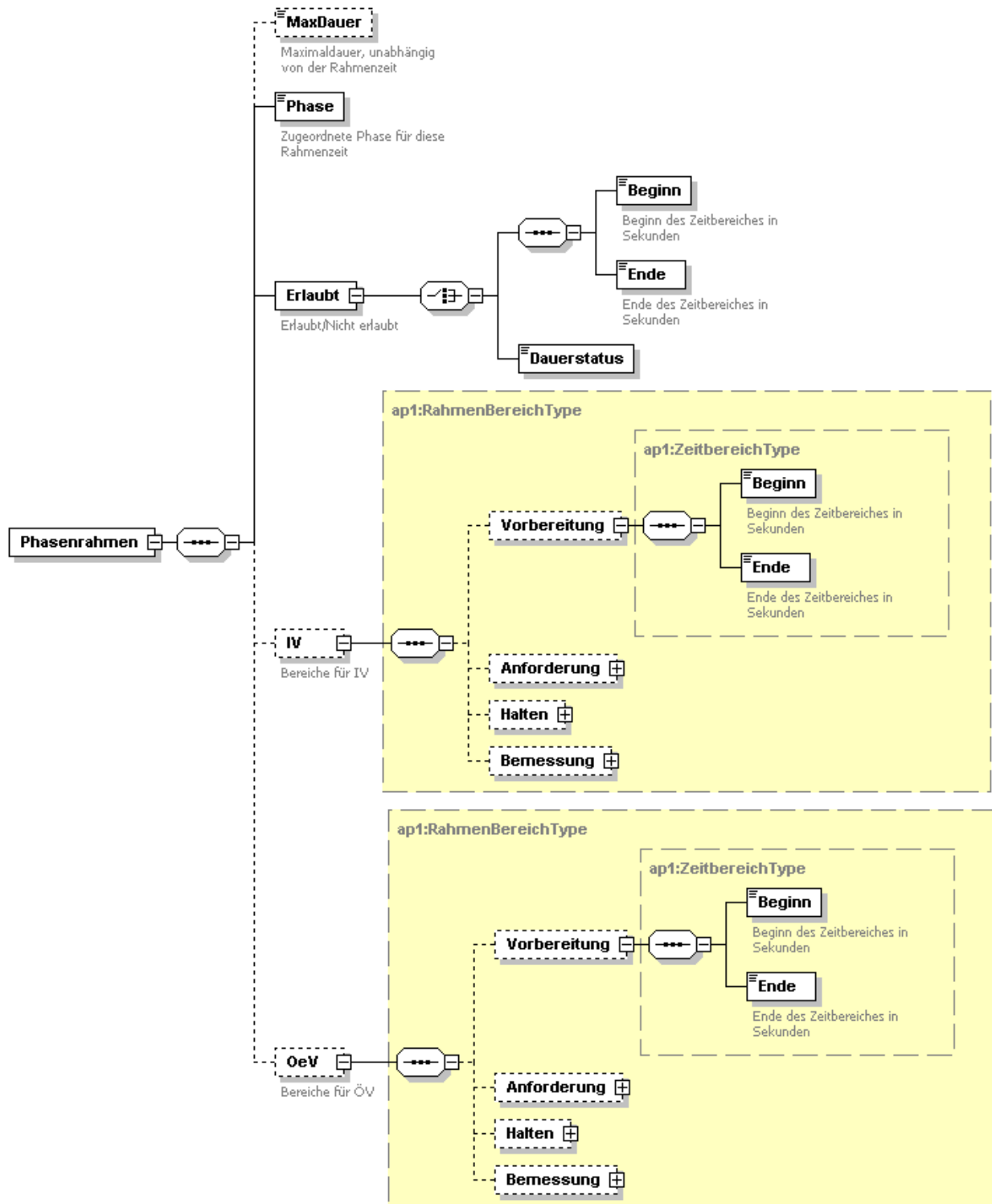

3.4.9.2 Signal group frame plan

Signal group frames indicate time intervals in which signal groups can be enabled.

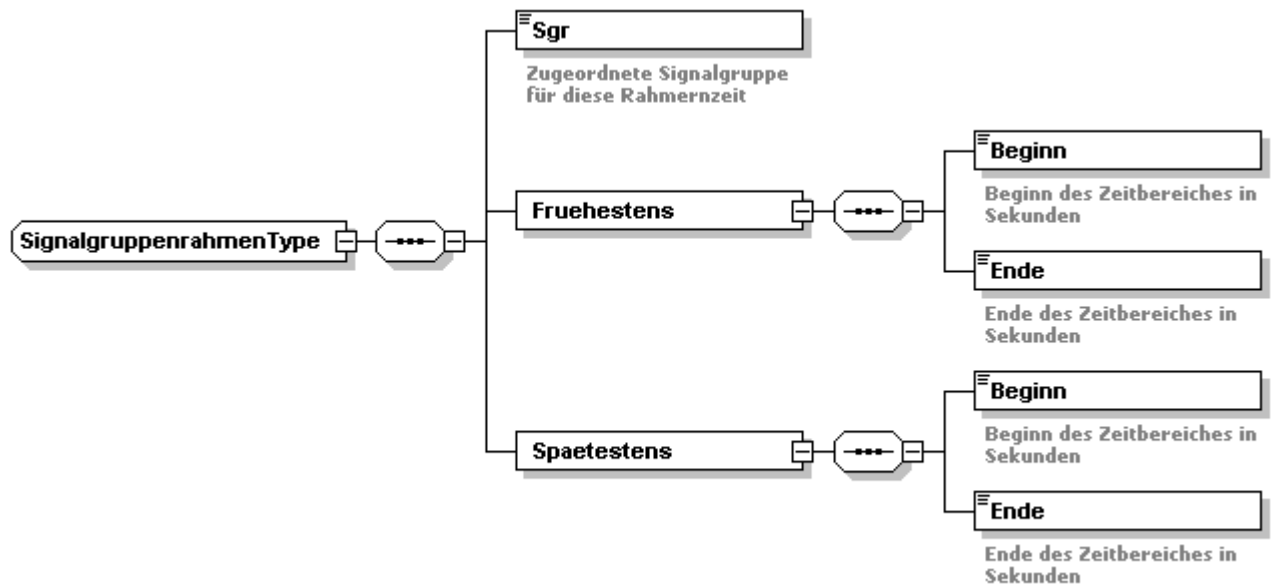

3.4.9.3 Traffic flow frame plan

Also included is the traffic flow frame plan, which contains the parameters needed by the TA process VS-PLUS.

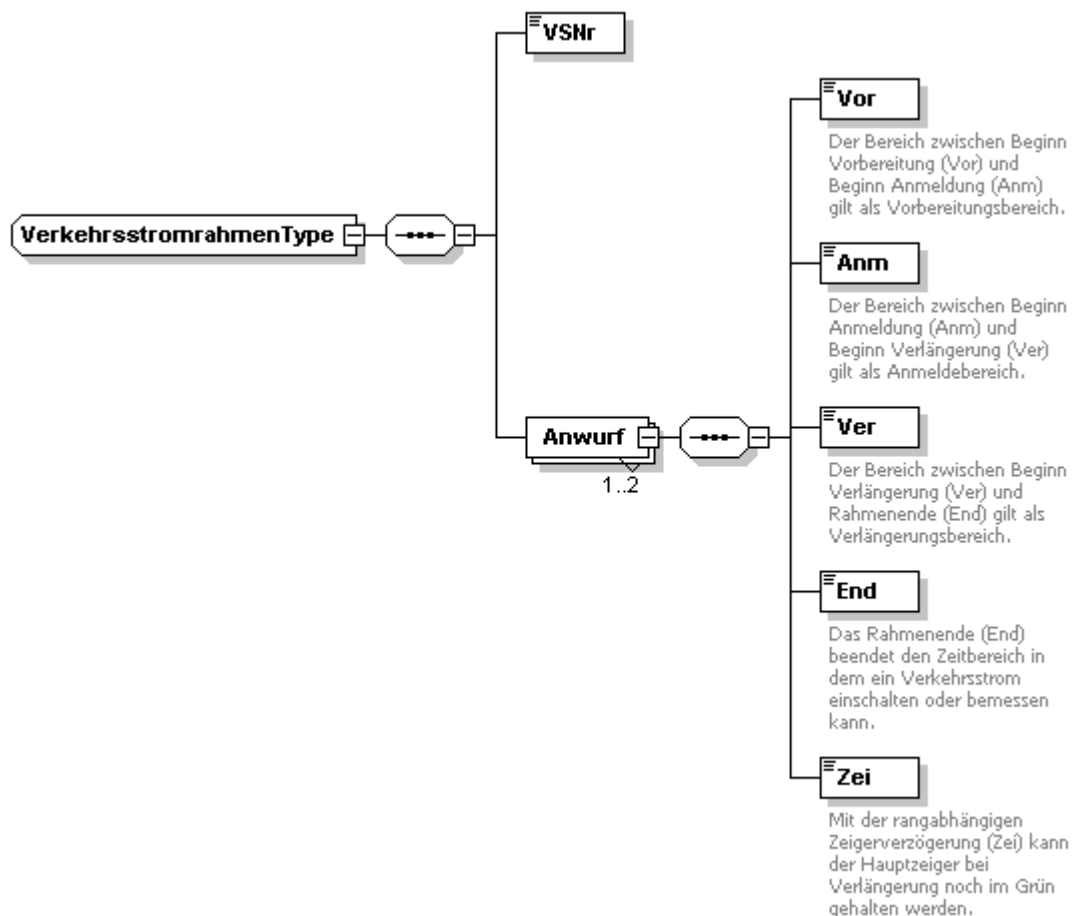

3.4.10 Control clock

The supply of the control clock consists of two parts: "Tagesplänen" set forth what commands should be carried out at what local clock time.

The remaining entries set forth what day plan should be carried out.

3.4.10.1 Week plans

Information is stored in week plans regarding what day plan should be carried out on what day. One reference is provided per weekday. The "StandardWocheplan" takes on a special status. It is always carried out when no exception arises. The remaining week plans are only used if they are selected by a "Sonderbereich". The OCITOutstationsNr of the Standard-Wocheplan must always be 1.

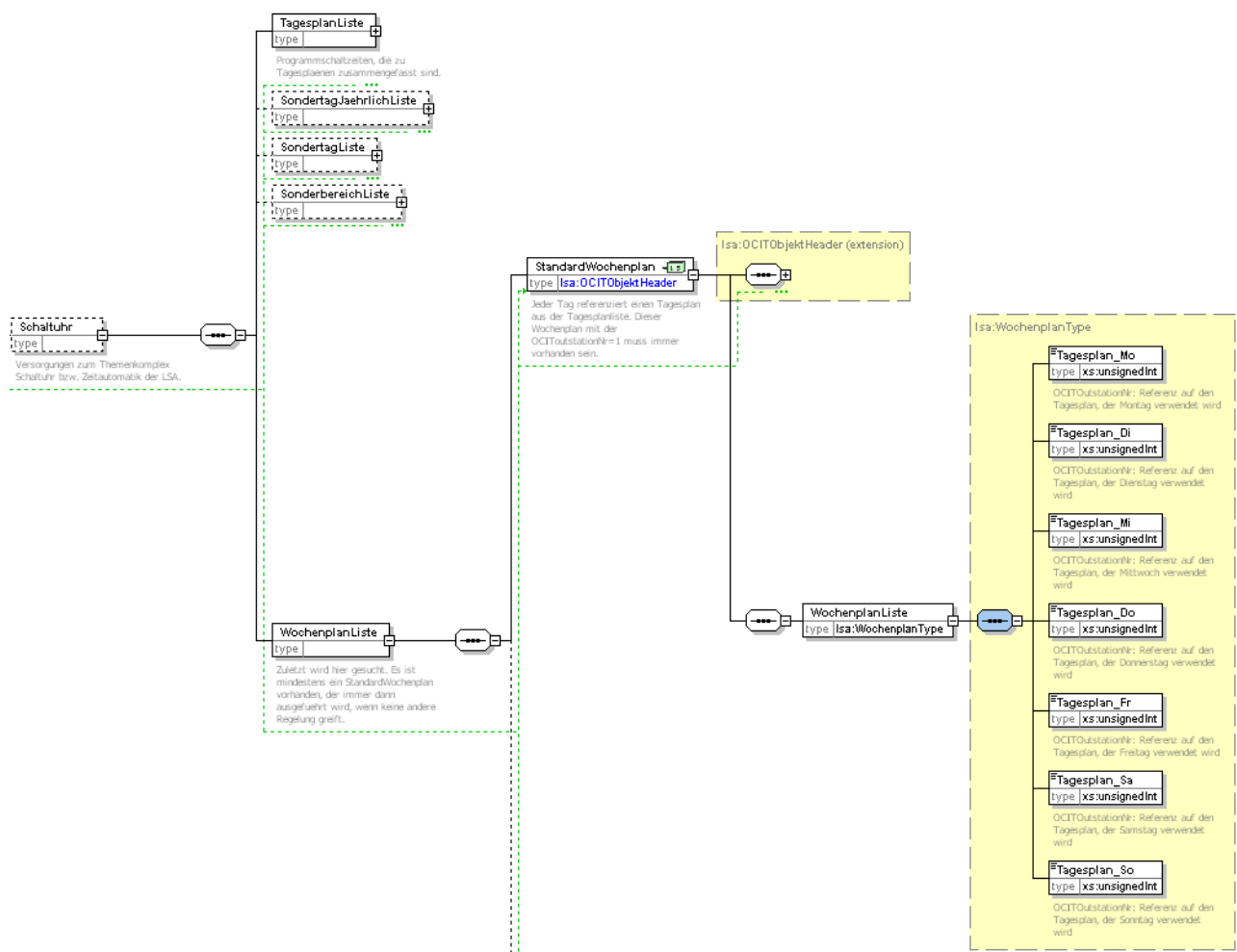

3.4.10.2 Special intervals

Special intervals are time intervals in which other week plans are activated. A special interval has a name and a time interval. A time interval can apply once or for each year.

The priority indicates what priority the special interval has in selecting the day plan.

For selecting the day plan, all special days and special intervals applicable to a day are taken and from these the element with the highest priority is determined. It is not permitted for two elements to have the same priority for one day. If this is the case, the selection of the day plan depends on the manufacturer. In any case, only one day plan is started.

The default is priority 1, i.e. the lowest priority. This priority is supported by all manufacturers. It is possible that the manufacturer also supports higher priorities.

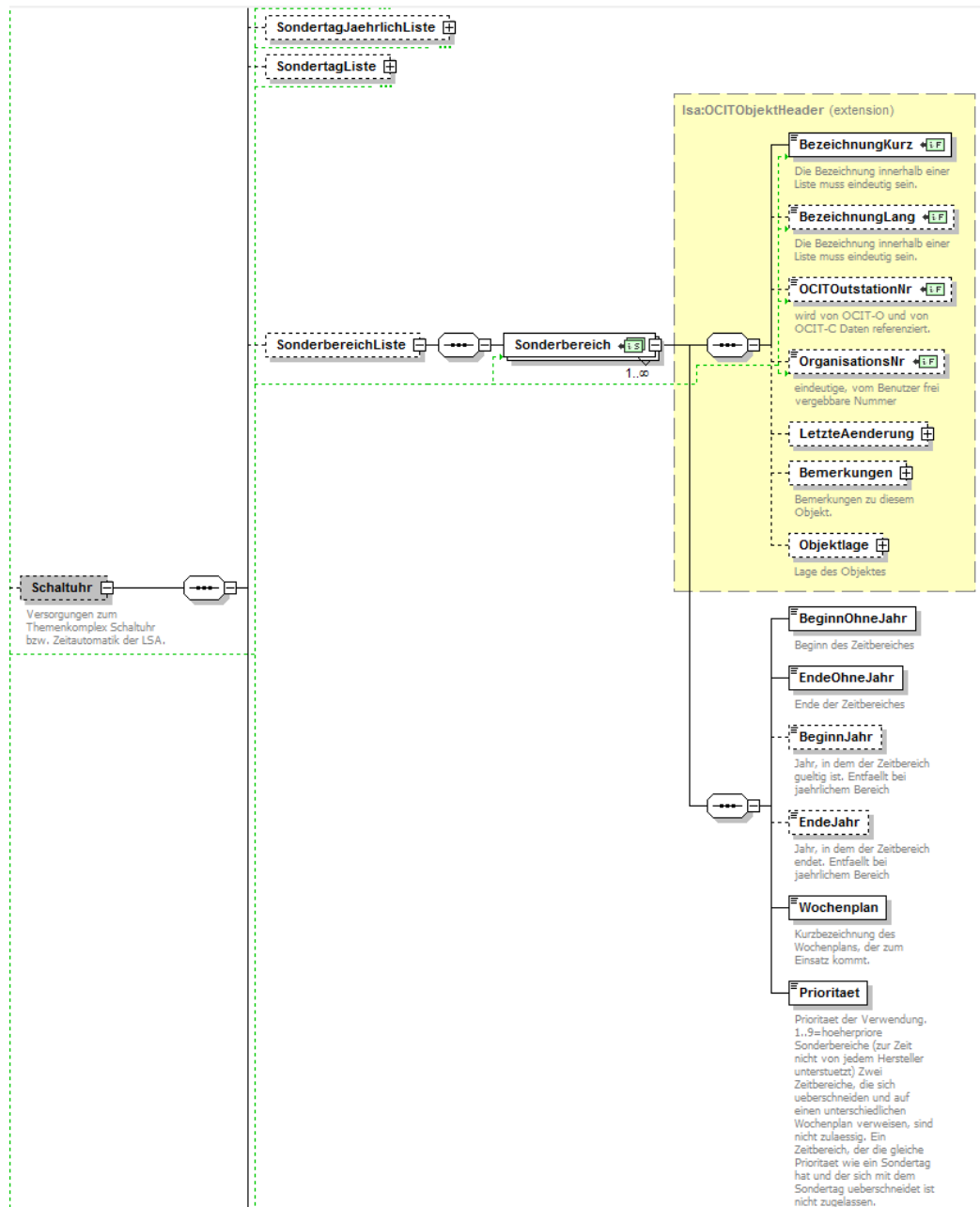

3.4.10.3 Special days

Special days are individual days on which special day plans are activated.

There are three options for defining a special day: One would be to define it as a fixed date and the other as an offset to Easter, which makes sense for many ecclesiastical holidays, and the third would be as a fixed day of the week from a set date (e.g. third Wednesday in November or in other terms: the Wednesday on or after November 15 or Sunday on or after 11/27).

The priority is comparable to the priority of special days. Priority 1 for normal holidays and 2 for special days is supported by every manufacturer. Other priorities, up to 9, may be possible depending on the manufacturer. It applies here too that two entries referring to the same day must have different priorities. Otherwise, the selection of the day plan is undefined.

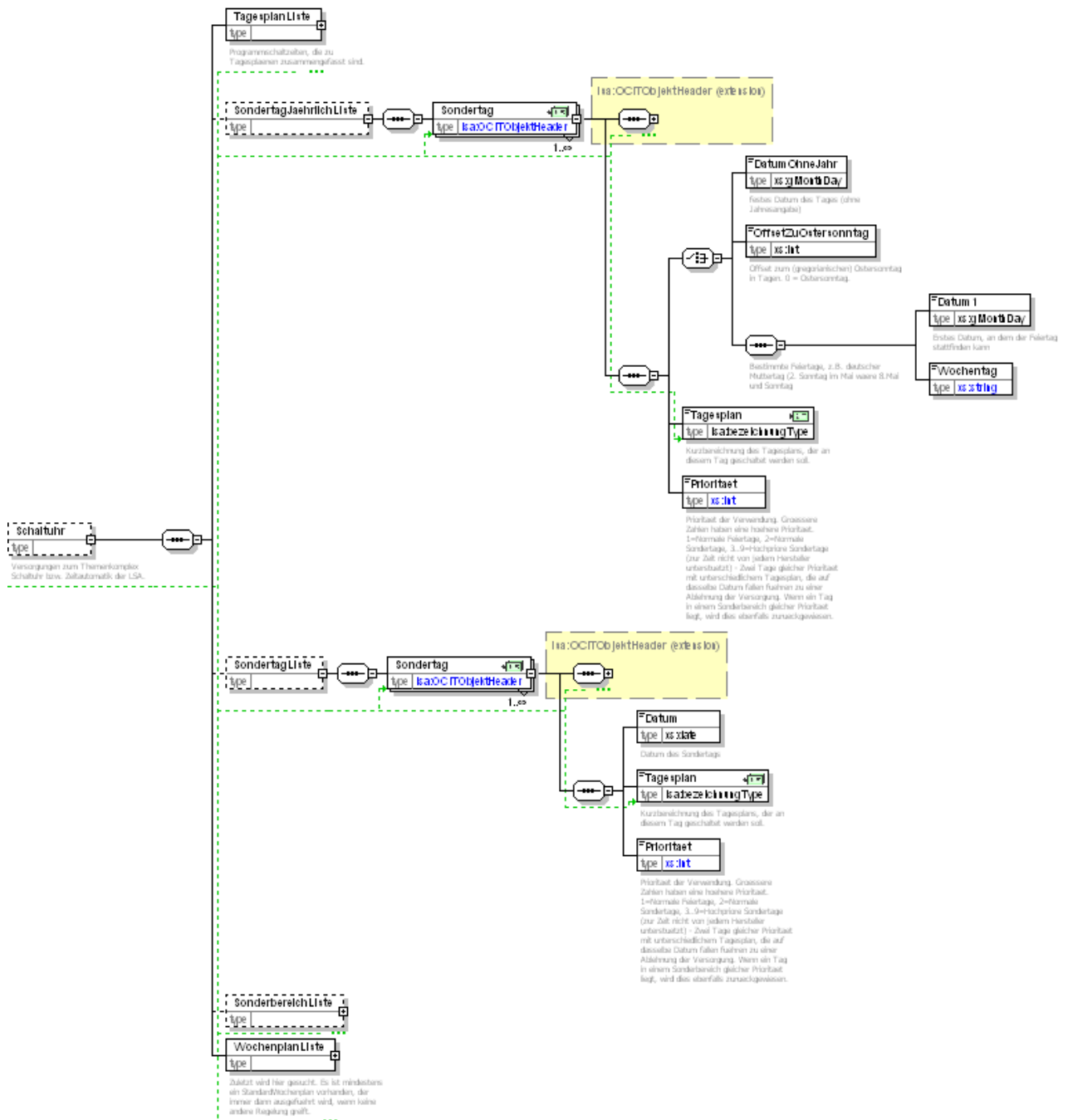

3.4.10.4 Day plans

The commands that are carried out throughout the day are saved in day plans. There must be at least one standard day plan. At least one command must be defined for each day plan. The OCITOutstationsNr of the standard day plan must always be 1.

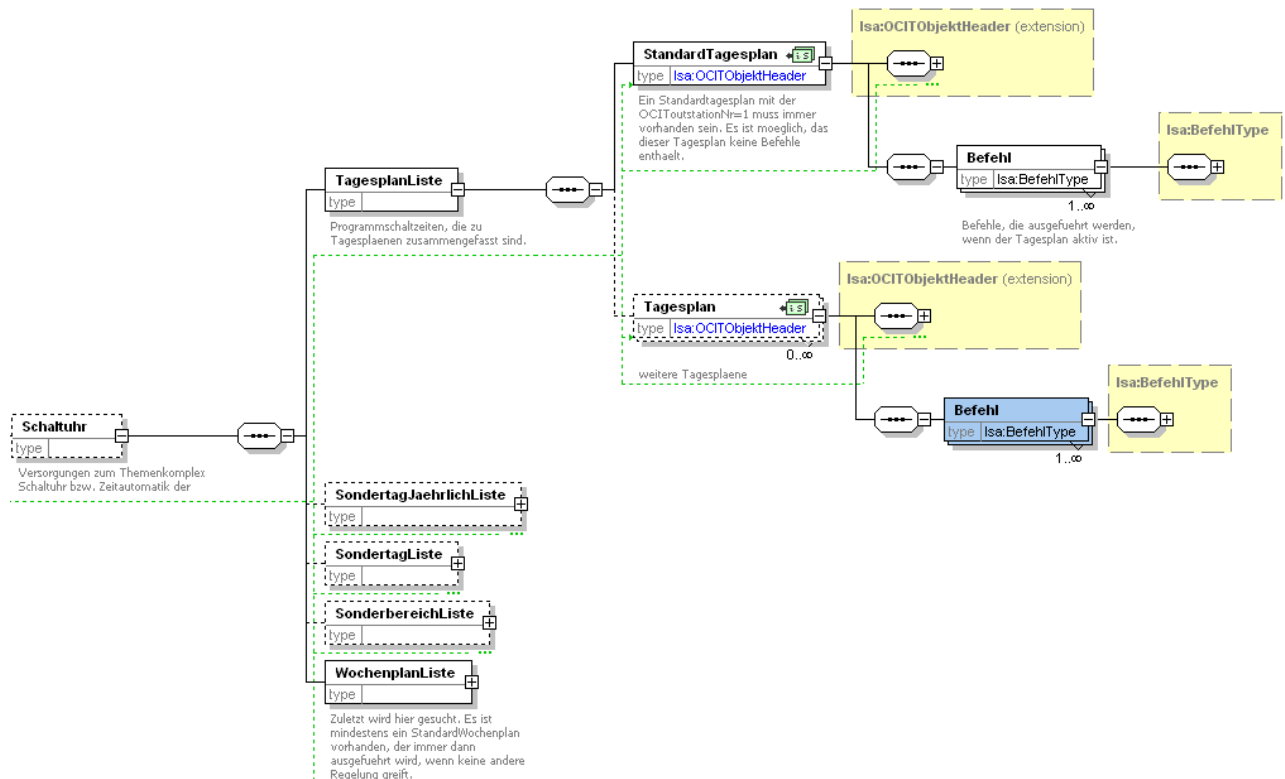

3.4.10.4.1 Day plan command

A day plan command consists of a time at which the command is started and the following switching options: Program, IntersectionOnOff, PartialIntersection OnOff (all available partial intersections are to be indicated here), the modifications for TA, PT and ITTA as well as 13 project-specific modifications, all of which are always to be indicated. If a modification is unknown, then it is always entered with OFF.

It may be that the controller, with OCIT-O V2.0 A04 or higher, acknowledges the command KnotenEinAus=AusDefault with the actual intersections status activated being AusBlinkenNeberichtung, AusDunkel or AusBlinkenAlle.

A total of 16 modifications are available. 3 modifications (TA, PT, ITTA) are already occupied; 13 modifications unoccupied for project-specific use via the control clock. This project-specific modifications each have a number within the range of 0 to 254. Occupancy recommendations are provided for 8 of them. They include the number and the name of the modification. Each project-specific modification can be turned On or Off.

Note: The applications activated with the modifications are not standardized and must be agreed upon on a project-specific basis.

Project-specific modifications to the control clock (occupancy recommendations)		
No.	Name	Remark
0	Orientation tone for auditory assistance for the blind	
1	Green light tone for auditory assistance for the blind	
2	Detector monitoring	If multiple monitoring times—e.g. morning peak, afternoon peak, normal traffic, light traffic—are necessary, then still unoccupied project-specific modifications must be used for this.
3	Digital output A	Indication of the channel numbers and DigAusgang::Get is not currently supported.
4	Digital output B	
5	Digital output C	
6	Digital output D	
7	TSS standby	For example, system off or all red.

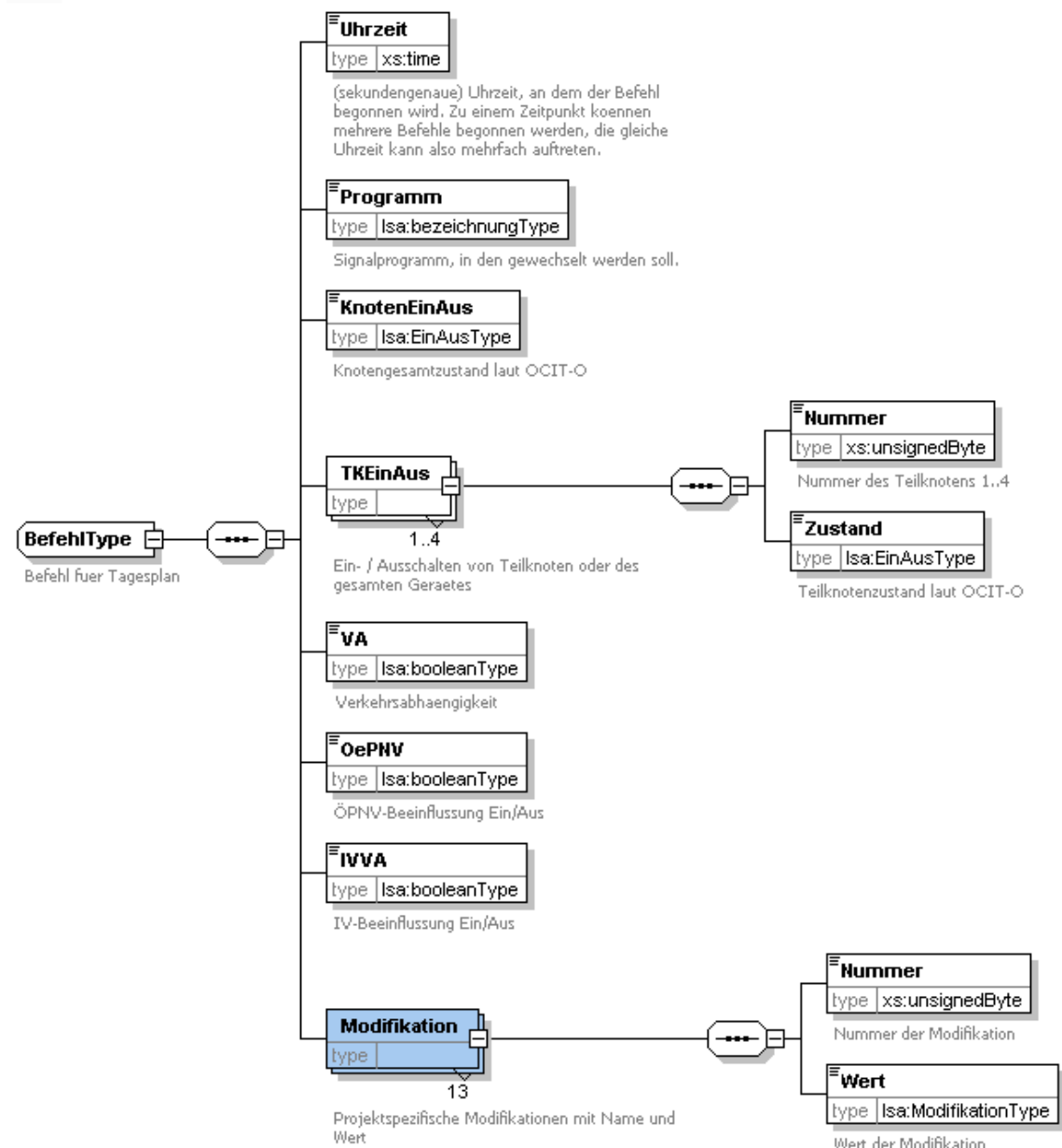

3.4.11 Signal group

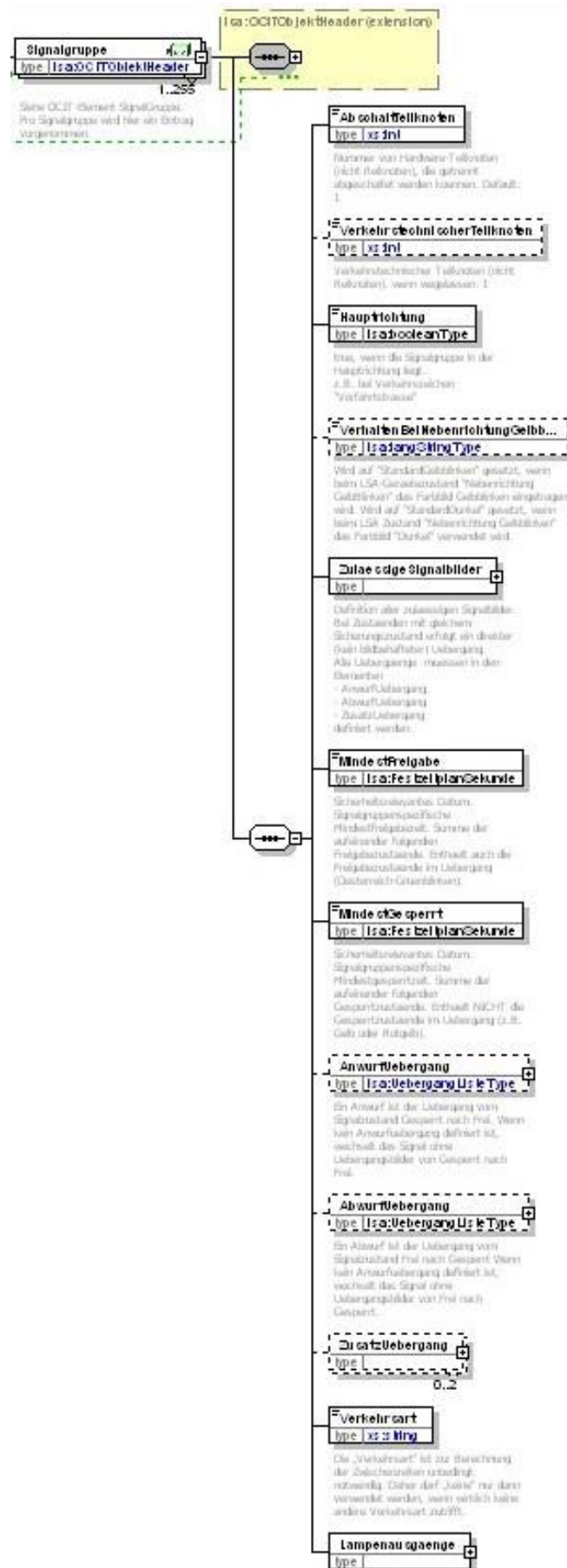

All data necessary for basic data supply are saved in the signal group. An explicit signal group type, however, is missing. The reason for this is that various signal group typings that cannot be directly mapped onto each other have come about in the past. Therefore, instead of a type, the data that could be derived from all the typings were accepted. This particularly includes:

- The standard go color and the standard stop color,
- The Anwurf and Abwurf transitions
- The permitted signal patterns and
- The traffic type managed by the signal group.

The manufacturer-specific typing is not saved. It can be supplied as a Nocit element based on the manufacturer.

The **AbschaltTeilknoten** indicates which signal groups can be deactivated together without the entire intersection having to be deactivated. Warning: The AbschaltTeilknoten has nothing to do with the "RelKnoten" from OCIT Outstations. The overall basic supply of an intersection corresponds to such a "RelKnoten". Systems that do not know this partial intersection enter a 1 here.

A **VerkehrstechnischerTeilknoten** sets forth what signal groups belong together in terms of traffic. If the value is not sent, it will take on the value 1.

The "**VerhaltenBeiNebenrichtungGelbblinken**" is only relevant if the primary direction is set and can otherwise be left out. If the value is set, it may not be left out by planning tools, even if the signal group is in the secondary direction because the value may be relevant to the signal group type.

In "**ZulaessigeSignalbilder**" all signal patterns that may be activated during normal operation are saved. Additionally, both standard signal patterns of the off state are to be entered here. The structure is described in more detail below.

MindestFreigabe and **MindestGesperrt** indicate the minimum times for green and red status. The minimum times are also used in the signal monitor. The Mindestfreigabe time indication also includes the green states of the transitions (signal pattern is classified under "Frei", "GreenFlashing" for example would belong to Mindestfreigabe). The Mindestgesperrt time indication, on the other hand, does not include the red states of the transitions (e.g. Yellow or RedYellow).

"**AnwurfTransition**" and "**AbwurfTransition**" include the standard transitions in Anwurf (red to green) or in Abwurf (green to red). These transitions are always used if no special transitions are indicated. The transitions consist of the signal colors and the fixed times. If a signal group can be activated with, for example, 3 seconds yellow and alternatively with 4 seconds yellow, the normal transition (e.g. 3 seconds yellow) is entered as the AnwurfTransition and the second transition as the Zusatzuebergang (see below).

All transitions that are possible for an AnwurfTransition or AbwurfTransition are to be entered as the "**Zusatzuebergang**". This applies both to different colors as well to different durations for which the colors can be displayed. Transitions between a "Frei" and a "Frei" state or transition between a "Gesperrt" and a "Gesperrt" state are not permitted.

The "**Verkehrsart**" is strictly necessary for calculating the intergreen times. This is why "Other" may only be used if truly no other traffic type applies. Otherwise, smooth exchange of data is not guaranteed. The following traffic types are permitted:

- Veh.
- Bus
- Tram
- Bicycle

- Pedestrian
- Blind person
- None

3.4.11.1 Permitted signal patterns

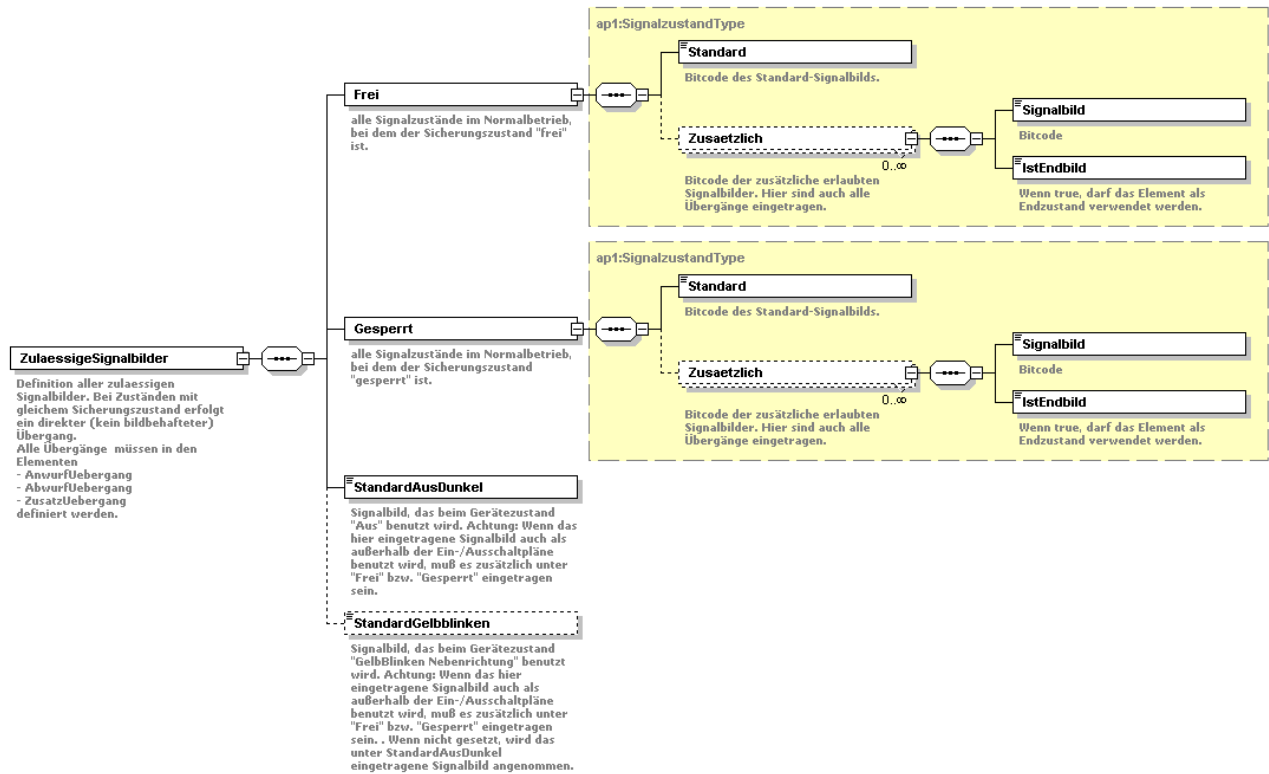

The permitted signal patterns include all signal patterns that can be displayed by the signal group as well as both signal patterns for the off state. This also applies to exclusively transition-related signal patterns, e.g. "Rotgelb".

In standardized form, only the traffic related monitoring states "Frei" and "Gesperrt" also used in intergreen time verification and offset time verification are modelled. A more in-depth modelling process of traffic-related states is not supported in the current version.

Some signal patterns, such as "Dunkel" can mean either "Frei" or "Gesperrt" depending on what signal pattern is active on another signal group. It must therefore be ensured that the traffic-related states "Frei" or "Gesperrt" are properly set for the case at hand!

3.4.11.2 Bit code

The bit code is defined in OCIT-O and is encoded in hexadecimal.

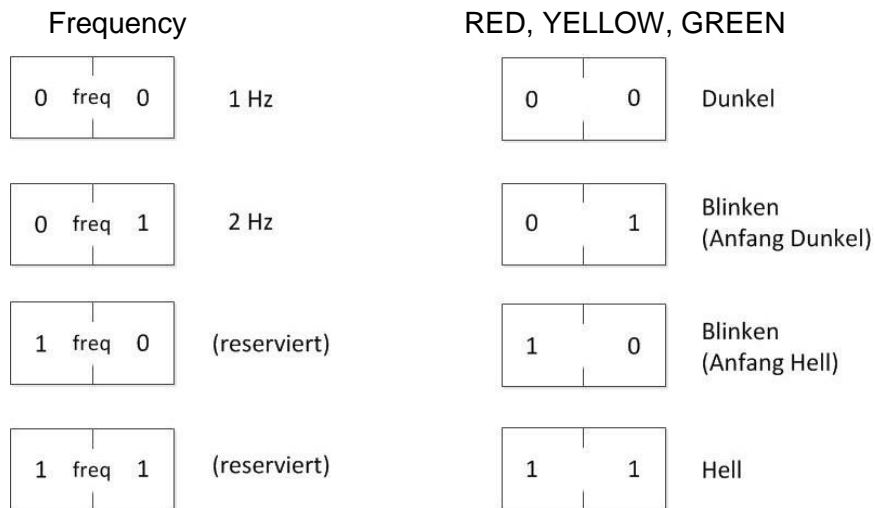
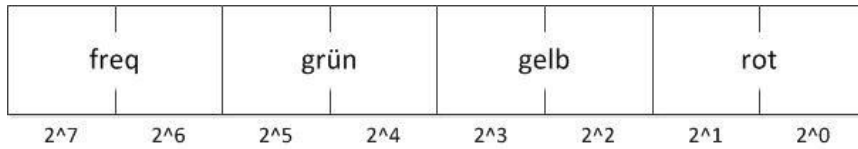

Examples:

dunkel	dunkel	0
roT1Hz	rot_blinken_start_dunkel 1Hz	1
rotgruen	rot gruen	51
rotgelbgruen2Hz	rot gelb gruen 2Hz	127
rotgelbgruen2R	rot gelb gruen reserved_2	255

The full table of signal patterns is shown in **Appendix 1:**

3.4.11.3 Anwurf and Abwurf transition

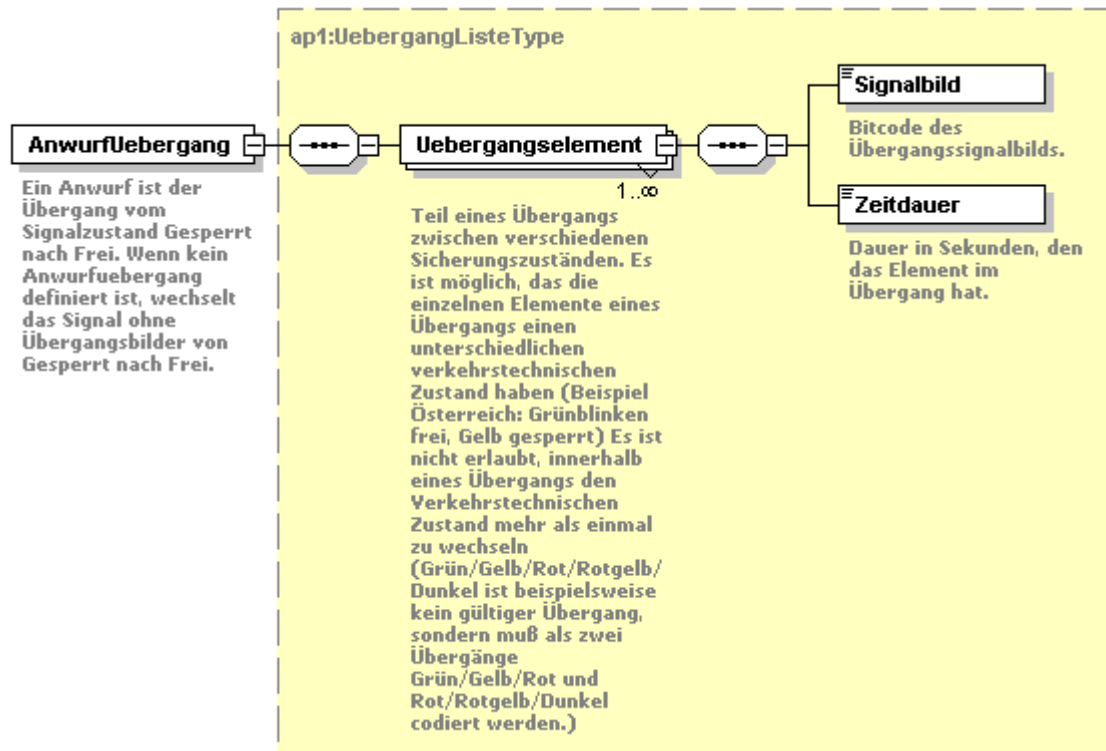

The Anwurf and Abwurf transition has the same structure. It consists of a list of signal patterns that are activated for a certain amount of time. The order of the signal patterns in the transition element list corresponds to their order in terms of time of the switching of the signal patterns. It is possible for individual elements of the transition to have a different monitoring-related state than others. In the AnwurfTransition, only signal patterns with the monitoring state "Frei" may follow the first signal pattern with the monitoring state "Frei". In the AbwurfTransition, on the other hand, only signal patterns with the monitoring state "Gesperrt" may follow the first signal pattern with the monitoring state "Gesperrt". All signal patterns must also be entered as permitted signal patterns.

The duration is set in the transition. A transition with the same signal patterns but another time duration must be entered as a separate additional transition.

3.4.11.4 Additional transition

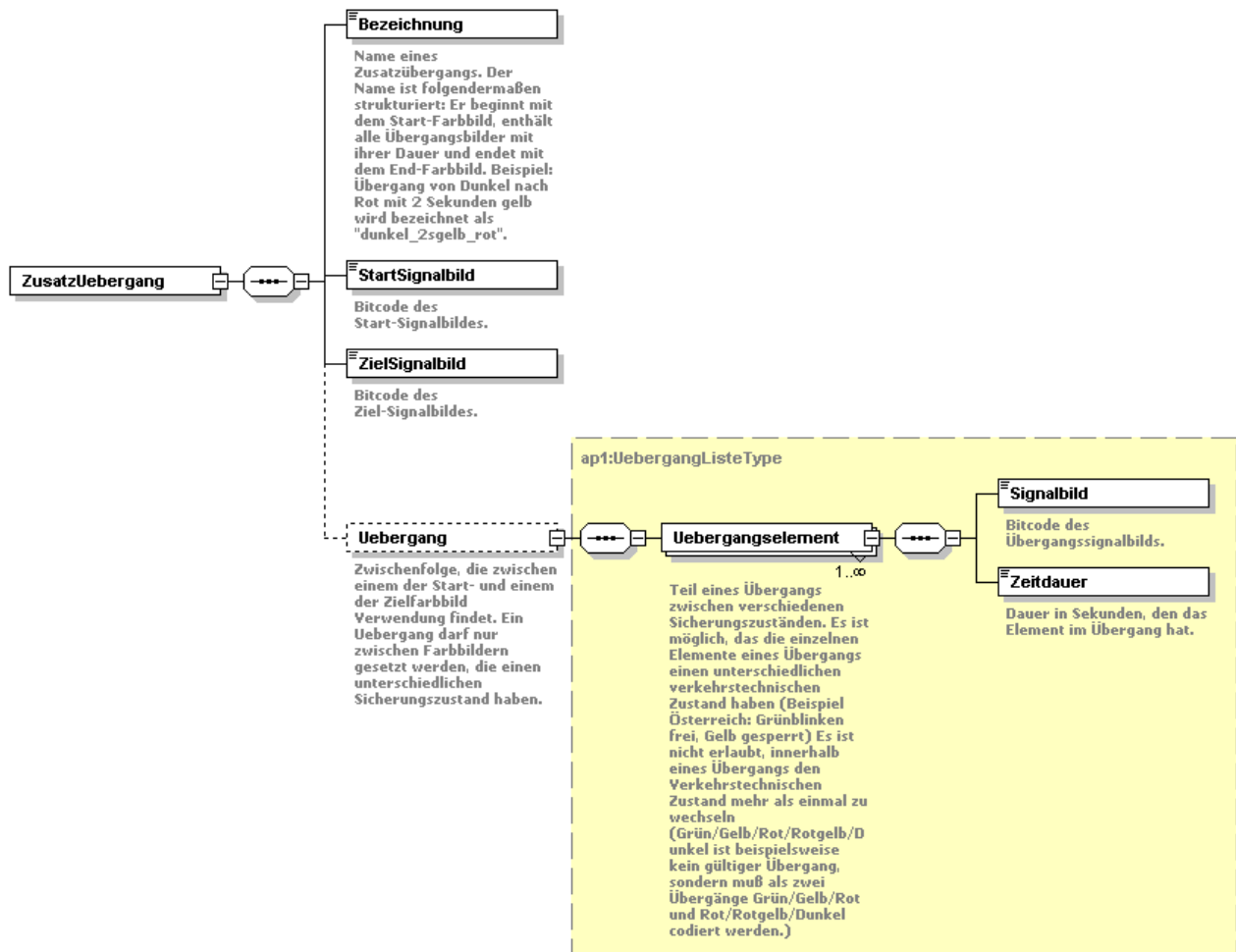

An additional signal transition is always defined between two exact signal patterns. The transition itself has the same structure as the Anwurf and Abwurf transition.

Indicating the start signal pattern and target signal pattern ensures that the transition is uniquely assigned exactly to this pair. If it is in particular a transition that has the same transition elements but with a different start pattern or target pattern that should be displayed, then a new transition has to be defined.

Naming the additional transition is also standardized to make the format easier to read. The name is composed of the bit code of the start-signal pattern, the names of all the transition-signal patterns including duration and the end-signal pattern.

A 3s "Gelb" in a transition from "Frei" to "Gesperrt" can, for example, be named "gruen_3sgelb_rot". Alternatively, instead of the symbolic name, the bit code can be used, but symbolic names are however preferred.

3.4.11.5 Lamp outputs

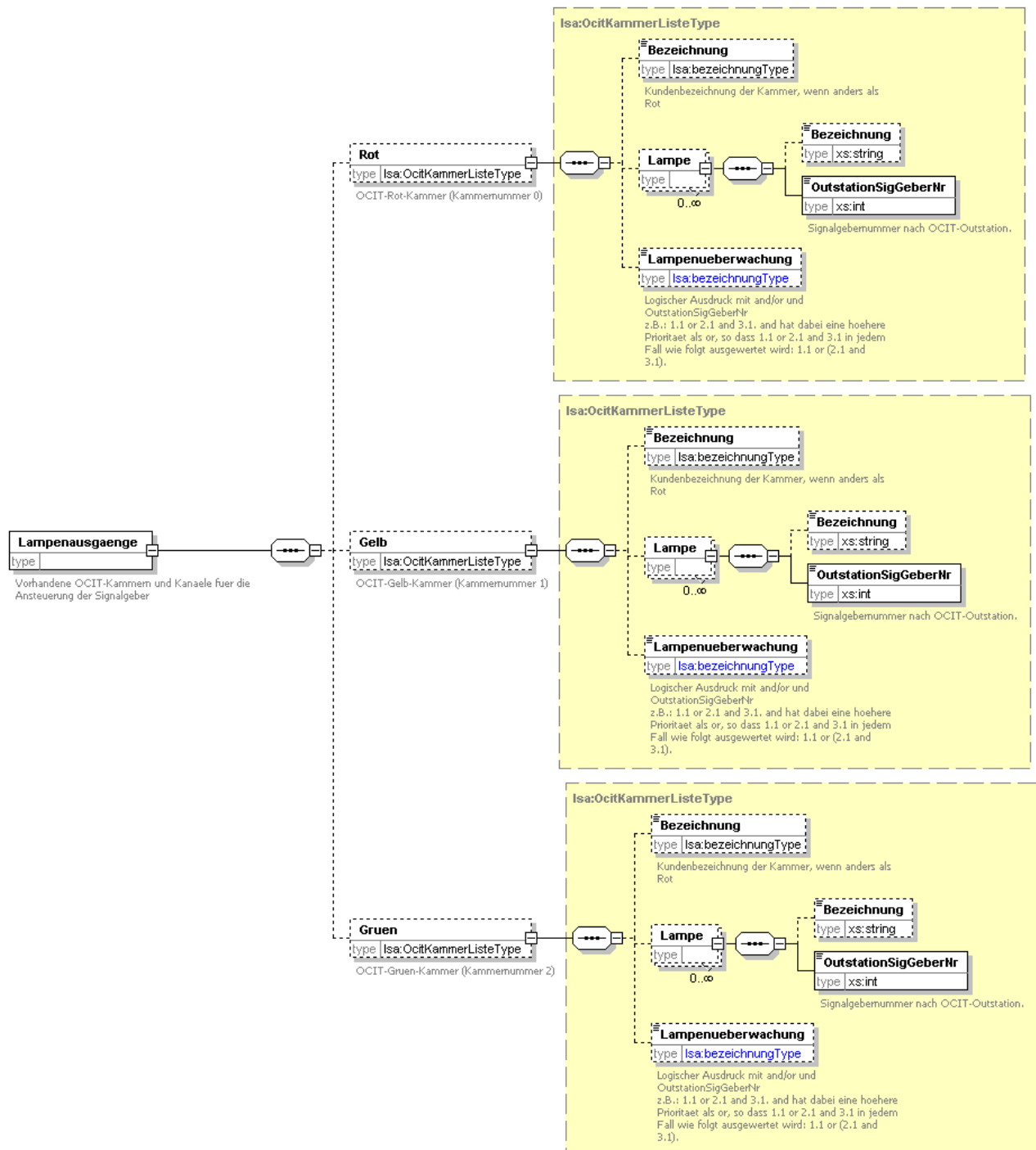

All signal heads can be described for lamp outputs. Because OCIT only support signal heads with max. 3 chambers, these are to be entered as "Gesperrt"(chamber number 0), "Gelb" (chamber number 1) and "Frei" (chamber number 2). One name can be supplied per chamber in case the signal group does not have the standard names "Gesperrt", "Gelb" or "Frei". Additionally, under "Lampe" the corresponding chambers are to be entered. A signal group, for example, with the chambers "Gesperrt" and "Frei" and five signal heads has five "Lamp" entries under Red and five under Green. The OCIT Outstations parameter Signalgeber-Nr is to be entered for each entry.

The lamp monitor only permits the collective monitoring of chambers of the same time. These are saved as a formula in the lamp monitor. Each chamber is indicated by the combination of Signalgeber-Nr / Kammer-Nr separated by a dot and can be combined with "and" and "or". "And" has higher priority than "or" here

Example:

Logical expression: 1.1 or 2.1 and 3.1
is evaluated as 1.1 or (2.1 and 3.1).

If chamber 1.1 or both chambers 2.1 and 3.1 fail, the lamp monitor reacts.
"2.1" here means: OCIT-Signalgeber Nummer = 2, OCIT Kammer-Nr = 1.

3.4.11.6 Special cases

The following special cases are depicted as follows in the data model:

The PT 4-point signal („Badehose“) is implemented with three signal groups with the color codes red, green, yellowblk.

The hop light (or "Springlicht") is implemented as a flashing light with the color code wbl_red-green.

3.4.12 Signal program

The signal program encompasses all signal programs used (not only the fixed-time programs). Activation and deactivation programs are modelled separately and are described further below. The header must in any case be filled out for traffic-actuated programs.

If the signal program does not reference the standard intergreen and/or offset time matrix, another matrix can be entered here.

If the signal program references the standard intergreen time matrix, the entry absolutely must remain empty.

This also applies to traffic-related minimum times. A reference to a traffic-related minimum times list for green and red can be indicated. The minimum times must, however, be equal to or greater than the safety-relevant minimum times. It is also possible to indicate a stage sequence plan which the signal program references.

Important references and essential times are to be entered in the header. The OCIT Outstations number entered for the signal program is the program no. There is no other mapping here.

Only one synchronization time is possible. Additional (manufacturer-specific) times, such as the advanced switching time points, sumi and stretch ranges available for Siemens are to be defined as Nocit-Objekte.

It is possible to indicate activation and deactivation programs via which the controller should activate and deactivate this plan. The name is to be used for these programs.

The times within the signal plan are to be noted in the planning tools from 0 to T_U-1 . Here the time T_U corresponds to the OCIT-Outstation-Zeitpunkt 0 because 0 and T_U coincide. Counting always begins at 0 (e.g. a new year begins with second 0).

Times within a range of seconds that cannot be resolved by a controller will be rounded up.

The content of the signal program can alternatively be indicated as a sequence of stage transitions at particular times or as the switchover itself. The name of the stage transition is also to be given as the stage transition. Important: The data within the stage transitions begin at time 0, not 1! A signal program may not contain any stage transition elements for a controller data supply, instead it must contain SP lines!

In case of a data supply for a controller, the signal program list must contain at least one element. Here it is irrelevant whether an activation, deactivation or signal program is concerned.

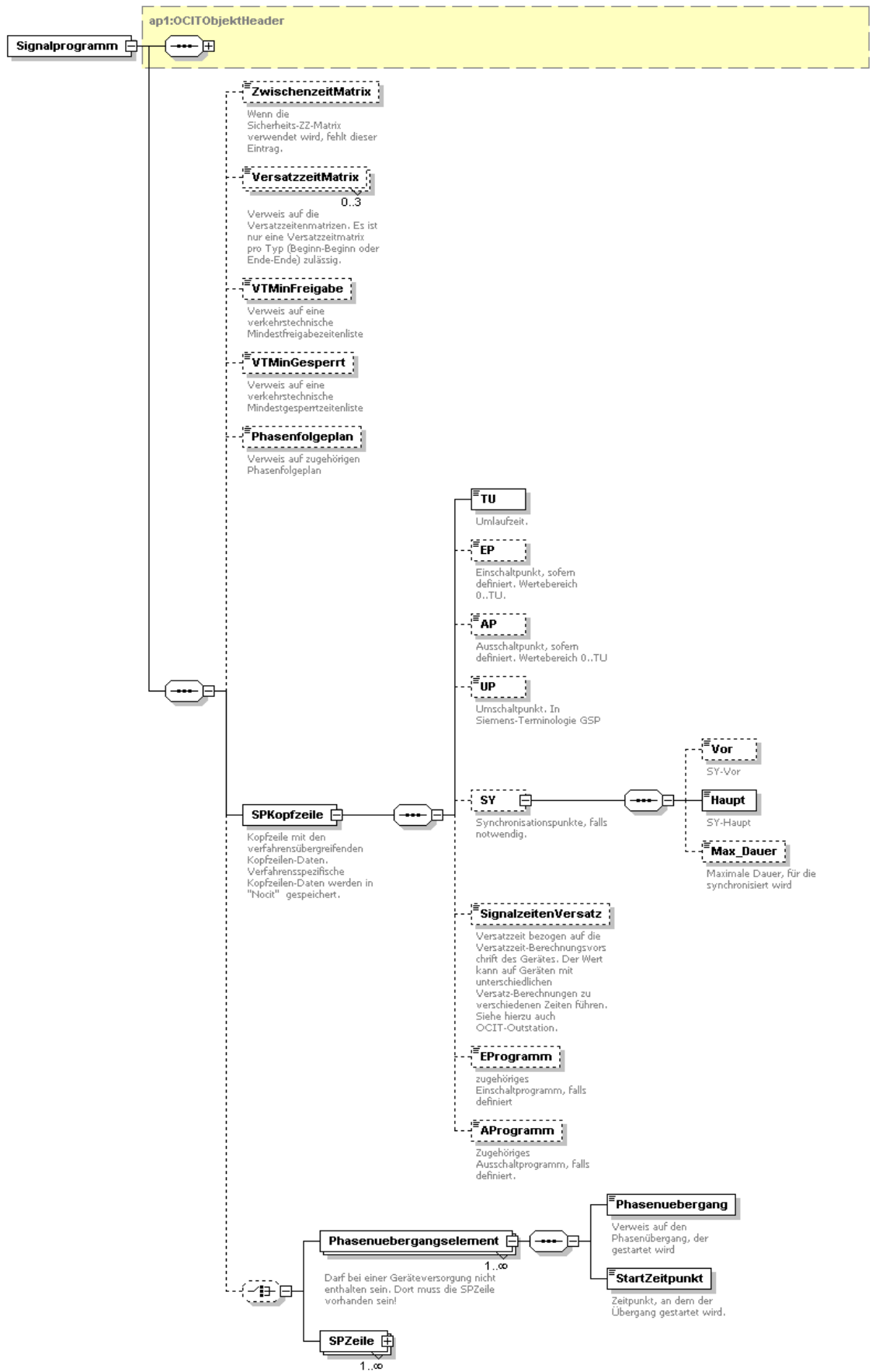

3.4.12.1 Signal program line

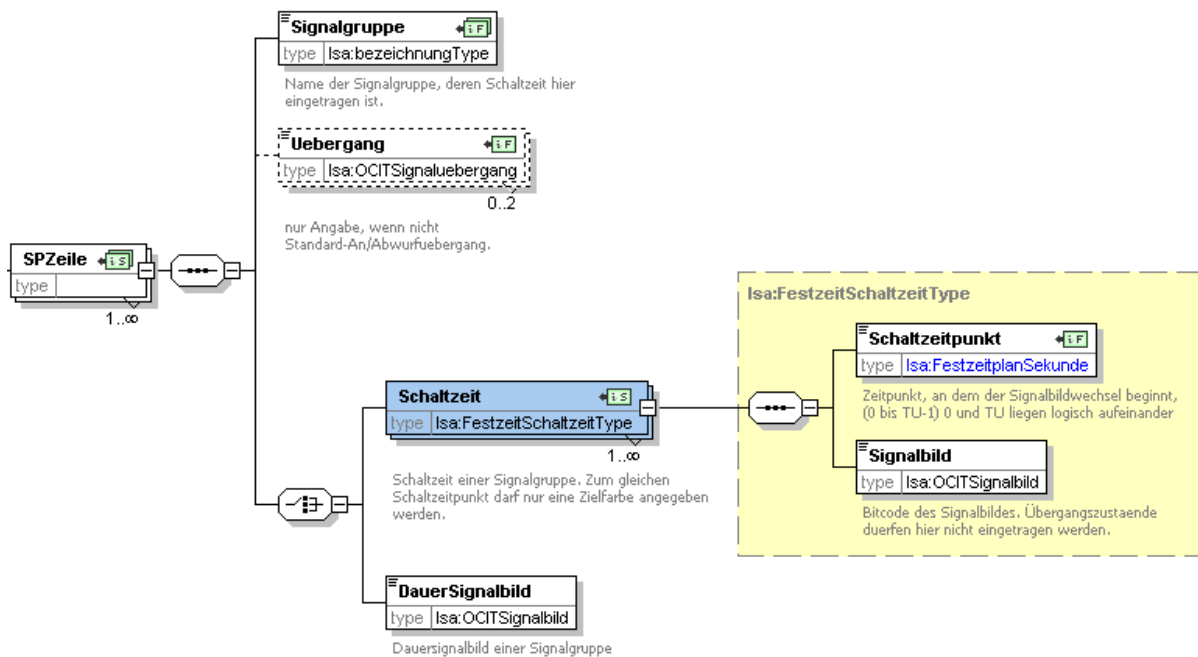

The actual switchovers are to be indicated per signal group. There may be at most one line indicated per signal group. The behavior of the traffic signal controller is not defined in the standard if a signal group is not included.

No transition signal patterns are to be entered as signal patterns, instead it is only the end states to be switched to. Example: A signal group has a yellow time of 3s and a red-yellow time of 1s. If for the switch time the following is entered:

- Switch time: 10 / signal pattern: green (hexadezimal code: 30)
- Switch time: 40 / signal pattern: red (hexadezimal code: 03)

the signal group ($T_U = 90$) reacts as follows:

- Time: 10s → Change from red to red-yellow
- Time: 11s → Change from red-yellow to green
- Time: 40s → Change from green to yellow
- Time: 43s → Change from yellow to red.

If the standard Anwurf and Abwurf transition should not be used, it is to be entered which "Uebergang" elements should be used. Only one "Uebergang" element may be indicated between two signal patterns here. A "Uebergang" element is not permitted between two signal patterns of the same monitoring state.

Continuous patterns should be entered as a DauerSignalbild. There is the option of indicating just one switch time per signal group if, for example, another switch is to be carried out via a logic (not defined in the standard).

3.4.13 Partial intersections

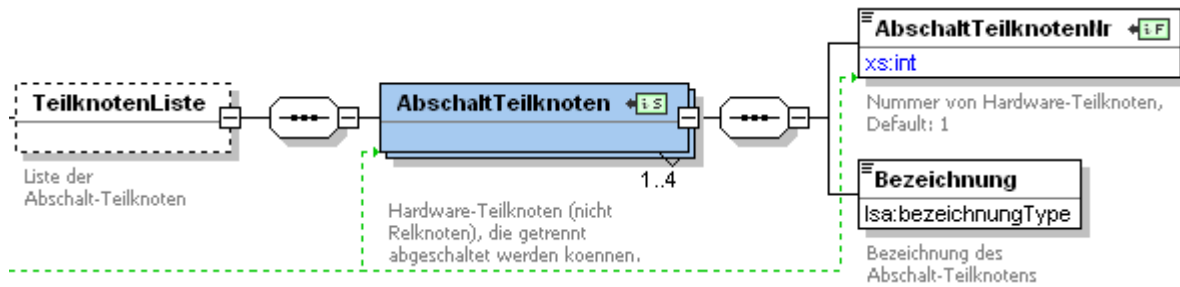

The partial intersection list itemizes partial intersections that can be deactivated separately from each other. In the signal group list, reference is made to this list via the partial intersection number.

3.4.14 Switch-on and switch-off program

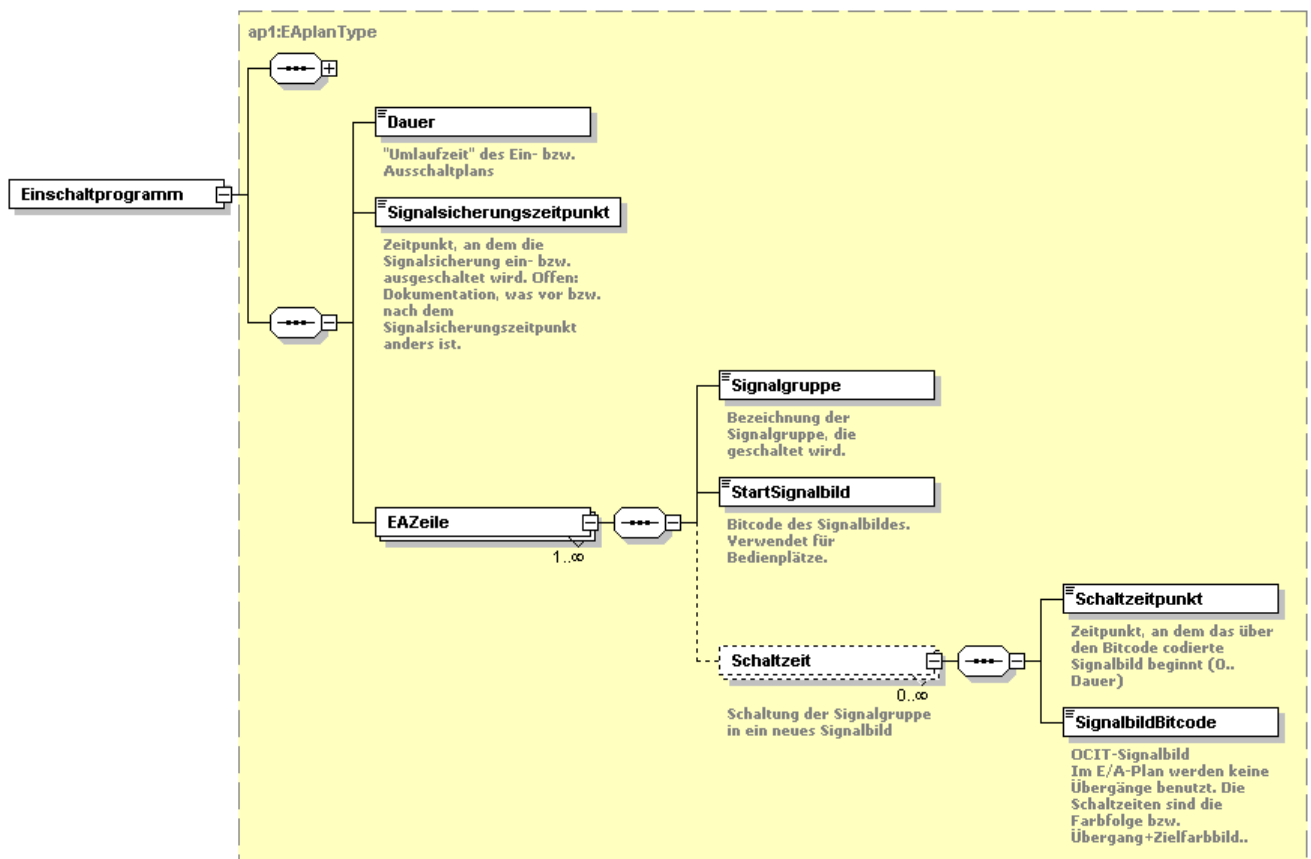

Switch-on and switch-off program have a structure different from signal programs. They have a signal monitoring time at which the signal monitor switches on or off (for the switch-on program the signal monitor switches on at this time and for the switch-off program it switches off). The time code begins with second 0 like in the stage transition.

What's more, switch-on and switch-off programs do not use any transitions, rather they contain all the transition patterns directly. When a signal group switches, for example, from dark via yellow-flashing (at time 5s) and yellow (at time 15s) to red (at time 18s), three times are to be entered:

- Switch time 5 / yellow-flashing (SignalbildBitcode:03)
- Switching time 15 / yellow (SignalbildBitcode:0C)
- Switching time 18 / red (SignalbildBitcode:03)

Additionally, a StartSignalbild is to be entered, which will be used only as an indicator in operator terminals. This pattern provides information about which signal pattern should be displayed before the first switchover takes place. The value is needed because this pattern is not known in every case. This value does not have any further technical significance!

A switch time should be indicated but is not compulsory at the zero second. Optionally however, the zero second can be specified.

3.4.15 Traffic-related minimum times

3.4.15.1 VTMindestfreigabeList

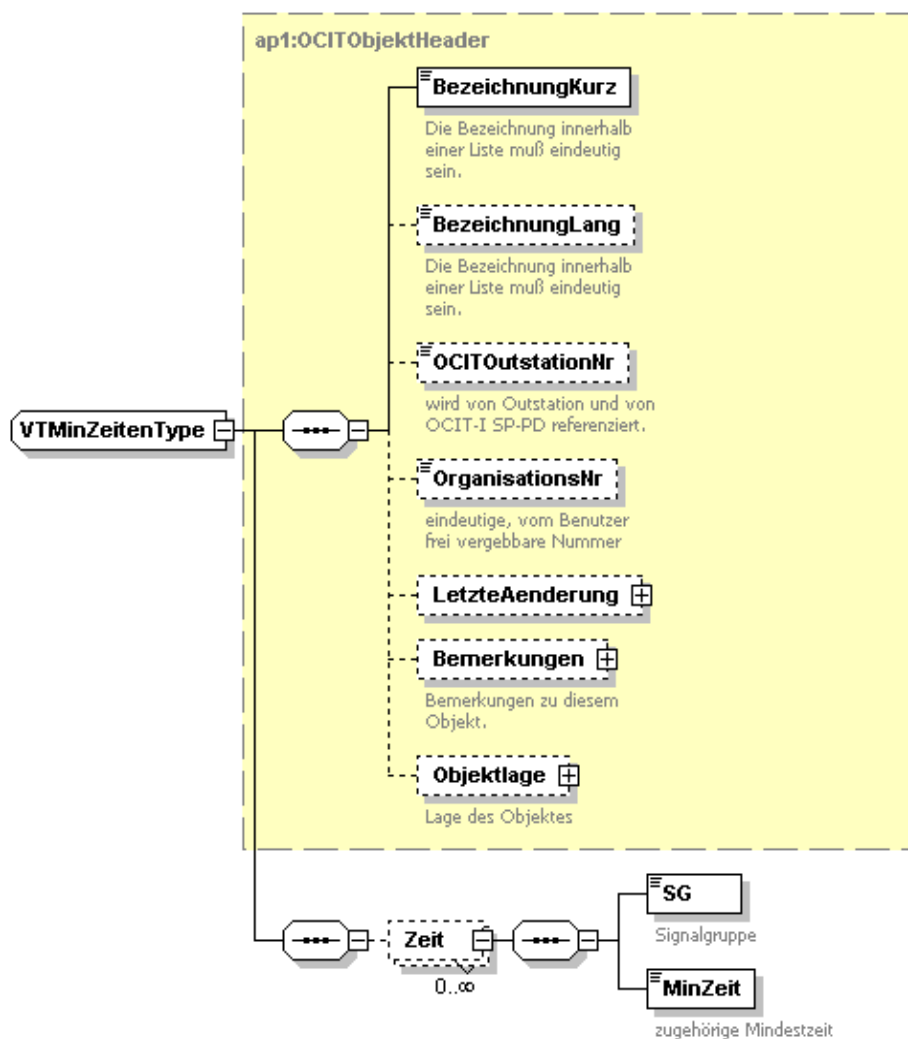

In addition to the safety-relevant minimum time that must be indicated for each signal group, up to 3 other traffic-related minimum time lists can be created. These must, however, must contain minimum times equal to or greater than the safety-relevant minimum time. How many matrices can actually be managed in the controller depends on the controller.

Such a minimum time list is used by referencing the desired list from the signal program.

3.4.15.2 VTMindestgesperrtList

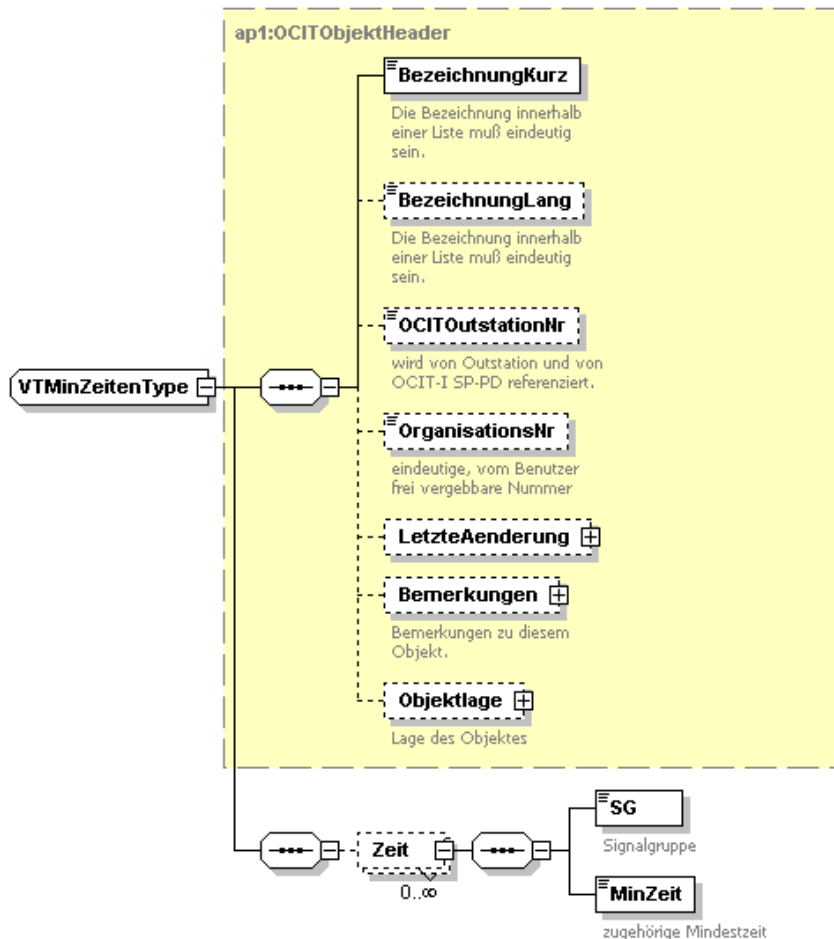

In addition to the safety-relevant minimum time that must be indicated for each signal group, up to 3 other traffic-related minimum time lists can be created. These must, however, must contain minimum times equal to or greater than the safety-relevant minimum time. How many matrices can actually be managed in the controller depends on the controller.

Such a minimum time list is used by referencing the desired list from the signal program.

3.4.16 Incompatibility matrix

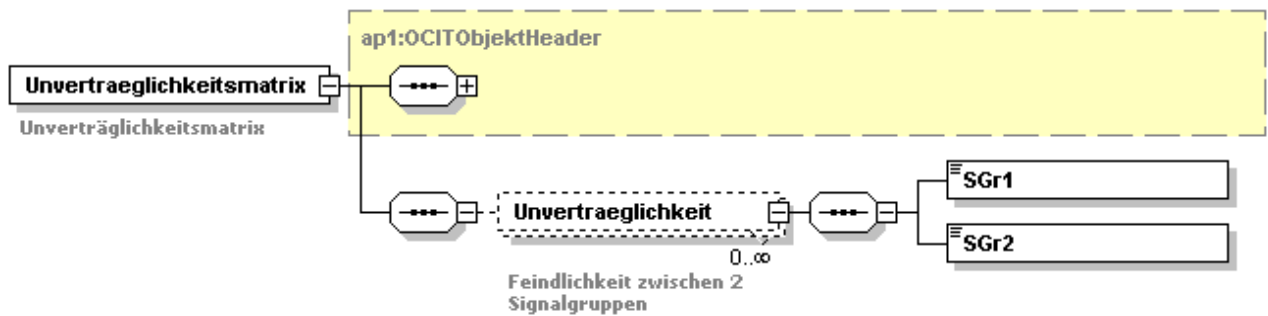

Signal group pairs incompatible with each other are to be stored in the incompatibility matrix. This matrix is also sometimes called a conflict matrix.

The incompatibility statement is always commutative. If signal group SGr1 is incompatible with SGr2, then SGr2 is incompatible with SGr1. It is possible for the same combination to be entered twice. Sgr1 / Sgr2 and Sgr2 / Sgr1. This double-listing does not have special significance. It is also not necessary.

3.4.17 Offset time matrix

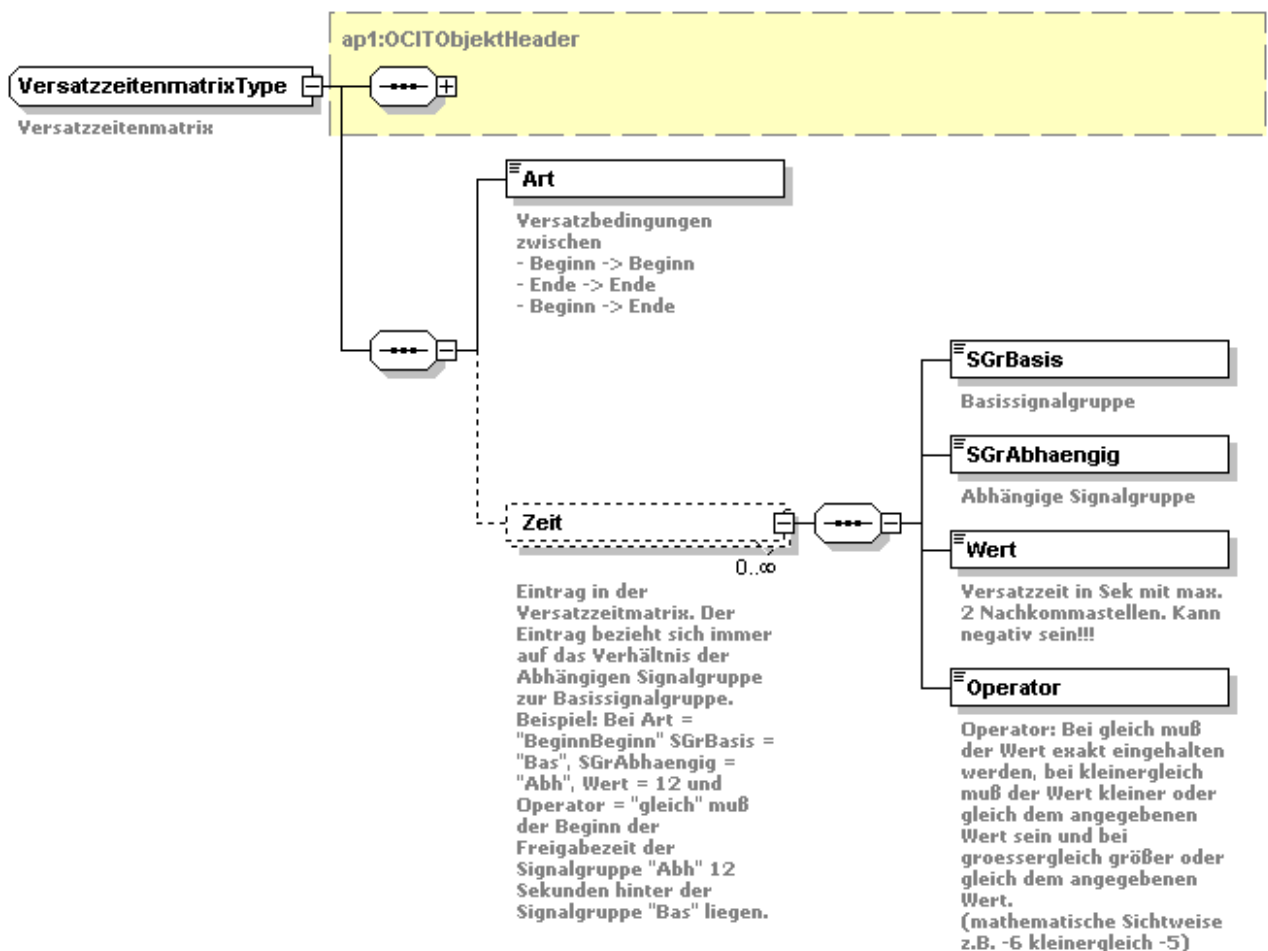

The offset time matrix covers both known offset matrices begin-begin and end-end as well as the rarely used offset matrix begin-end. (The offset time matrix end-begin is the intergreen time matrix).

For each type, up to three matrices can be defined. How many matrices can actually be managed in the controller depends on the controller.

The numbering of the offset time matrix is free and may have gaps.

SGrBasis and SGrSlave is a pair of signal groups between which a dependency is entered. It is not possible for the same signal group pair to be entered in the same matrix with their roles reversed. Therefore, if signal group B is entered as the basis in one matrix and signal group A as the slave, then in this matrix signal group A may not be entered as the basis and signal group B as the slave.

Time is to be indicated in seconds, negative times are permitted.

"Greater than", "less than" and "equal to" are potential operators depending on if the offset time must greater than or equal to, less than or equal to or equal to the value indicated.

"Greater than or equal to" 5, for example, means that the offset time between the two signal groups must be greater than or equal to 5 seconds.

Note: The description of the potential offset variants is depicted in the document OCIT-O_Lstg_V3.0

3.4.18 Intergreen time matrix

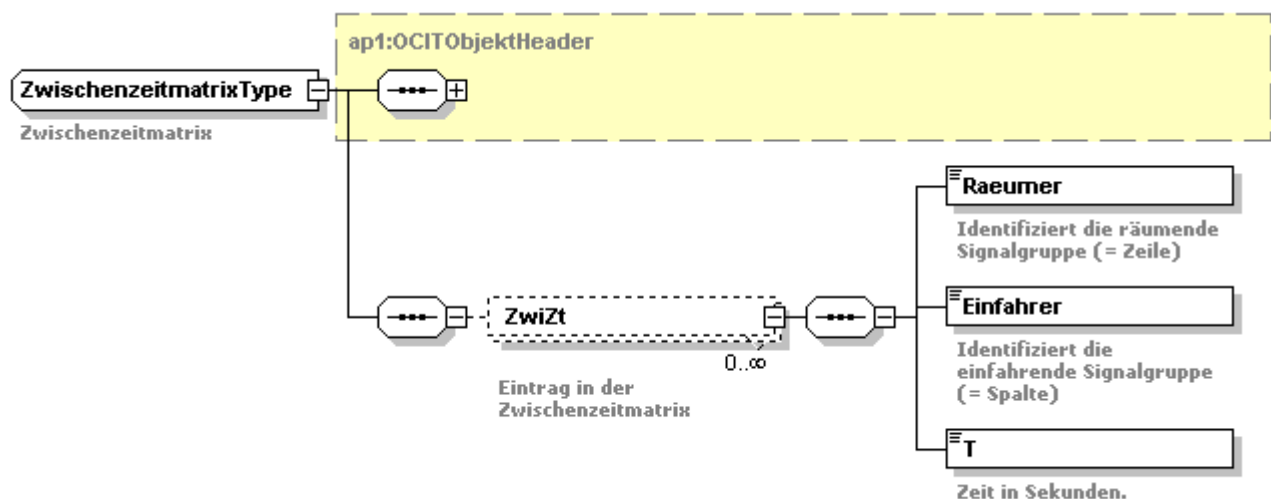

The intergreen time matrix contains the intergreen times between the signal groups. It is possible here that a signal group pair comes up in a reversed combination because the intergreen times may be different for both combinations.

Negative times are not permitted in this matrix.

There are two types of intergreen time matrices: The safety-relevant intergreen time matrix is constantly being checked by the traffic signal controller; if this matrix is violated, this leads to immediate shutdown.

Note: In OCIT-O the safety-relevant intergreen time matrix is always no. 0. In OCIT-C no number may be entered!

The remaining intergreen time matrices are intended, for example, for poor weather conditions. They must contain all the entries of the safety-relevant intergreen time matrix, and all times must also be greater than or equal to those of the safety-relevant intergreen time matrix. How many matrices can actually be managed in the controller depends on the controller.

3.4.19 NocitList

In the NocitList, data are saved that are relevant to individual planning tools as well as to traffic signal controllers but cannot be standardized. For example, these may be expansions to the basic data supply:

Objects in the NocitList are processed by the gateway in a standardized way: All Nocit parts are included in transmission.

The substructure of the Nocit object must be depicted in a schema included in delivery by the manufacturer of the planning tool. If the structure should not be revealed, the data can be stored encoded as base 64. The planning tool-specific Nocit structures are in no way subject to standardization here and can be modified at any time by the manufacturer of the planning tool without justification.

3.4.19.1 Project-specific Nocit structures

In addition to the planning tool-specific Nocit structures, there is the technical option of defining Nocit structures on a project-specific basis and storing project-specific data in it. This way, you can do without the need to transport project-specific expansions in auxiliary files. A project-specific ID will then be defined as the ID.

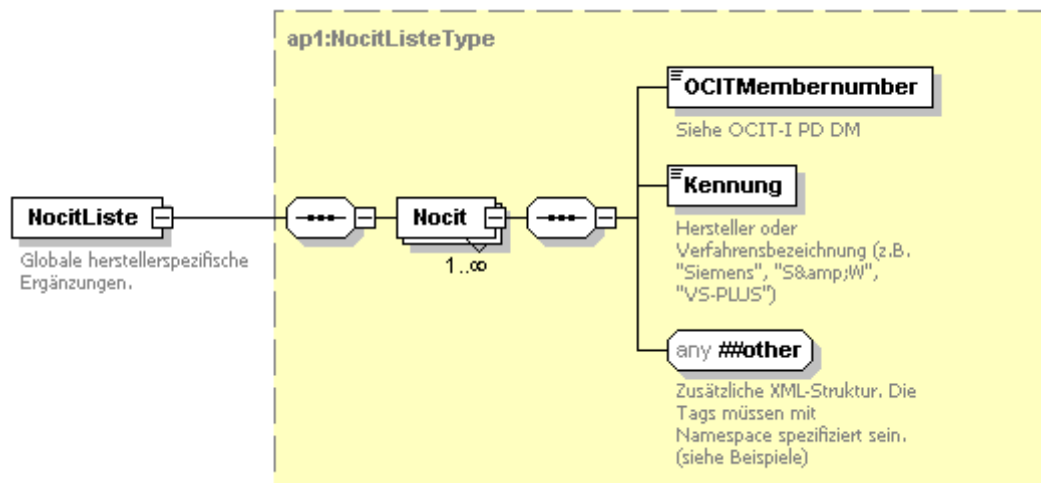

4 Versioning and data security

4.1 Introduction

4.1.1 Versions

Assigning versions to supply data for a unit takes place both as a whole (complete version) as well as block by block (subversion). Blocking follows the allocation of planning and supply data (see Figure 3: Schema of the supply data blocks and version data of the user supply). It is to be defined on a project-specific basis whether block-by-block version assignment is to be functionally applied. Otherwise, the version of all blocks will always be incremented "im Gleichschritt".

Blocking for the standard portion of the supply data is specified in the standard. A block always consists of a "klasse" (e.g. fixed time control) and never of "Instanzen" of a class (e.g. individual signal programs).²

Every change to a subversion inevitably leads to a change in the complete version.

4.1.2 Process

The OCIT-C data model TSS supply data can be filled from multiple sources. Multiple sources, for example, can be two traffic-related supply tools or planning tools of which a tool is responsible for supplying fixed time signal programs, while the other program is needed for the traffic-actuated logic.

Because the dependent supplies are only valid if the basic data remain unchanged, it is not only necessary to know the data source but also to be able to identify the validity of the data from other tools.

In this regard, the mechanisms described in the following are to be provided:

4.1.2.1 Planning process

the following information is to be stored in the file intersection_config_data.xsd:

- The checksum and checksum info about the data divided into various blocks (see section 4.5)
- The version designation to be assigned by the planner (field <Planungsversion>)

4.1.2.2 Supply to the controller

The controller makes at least the following information available:

- Calculation of the checksum in the controller
- Formulation of the build ID in the controller
- Return of the following information from the controller:
 - Controller checksum
 - Controller build ID
 - Transmission time

² Otherwise, version assignment and data storage would also be much harder in the supply tool.

- Fully Qualified Domain Name (FQDN) or IP address if FQDN cannot be resolved.
- Activation time

The specific data of the transmission log are presented in chapter 5 "Communication log".

4.2 Frame and header

There are three different files for the supply data and the information about block assignment of the supply data:

- Schema of the supply data
("XSD Versorgung", File name: *intersection_config_data.xsd*)
- Schema of the block assignments
("XSD Blockzuordnung" File name: *intersection_config_data_block_assignment.xsd*):
The schema file defines in what form block assignments will be written.
- Definition of block assignment
(XML Block Assignment, File name: *intersection_config_data_block_assignment.xml*):
The XML file defines how the elements of the XSD config data are assigned to the blocks.

Allocation is necessary for it to be possible to change the block assignment regardless of the model of the supply data.

4.2.1 Supply data

The XML file for the supply data consists of at least two parts: An XML header, which most importantly indicates the encoding of the file, and an XML element, in which all the data are stored. For the OCIT-I data supply, the standard namespaces from which the OCIT-I-VD configuration file is composed are also indicated in the header.

The frame of the OCIT-I-VD configuration file appears as follows (the colors and line breaks are put in for clarity):

```
<?xml version="1.0" encoding="UTF-8"?>
<OIVD
  xsi:schemaLocation=http://odg_und_partner/intersection_config_data inter-
  section_config_data.xsd
  xmlns="http://odg_und_partner/intersection_config_data"
  xmlns:n1="http://www.altova.com/samplexml/other-namespace"
  xmlns:xsi="http://www.w3.org/2001/XMLSchema-instance">
  <GrundversorgungsdatenLSA>
    - Here are the standardized supply data -
  <NocitListe>
    - Here are the manufacturer-specific supply data expansions -
  </NocitListe>
```

```

</ GrundversorgungsdatenLSA>
<LichtsignalsteuerungVersorgungVAVerfahren>
  - Here are the data for traffic-related processes -
</LichtsignalsteuerungVersorgungVAVerfahren>
<Checksummen>
  - Here are the data for checksums -
</Checksummen>
</OIVD>

```

The blocks marked with colors are also data with an XML structure that are entered at this position and have been explained in the first part and are explained further in this part.

The part marked in blue is optional and contains the necessary information for automated testing of the data. Its contents consist of pairs of lines for which the first line indicates the namespace and the second line indicates the file in which the namespace is specified. The example assumes that the schema files are stored in the same directory as the XML file. Each tool is free to enter this "xsi:schemaLocation" entry according to its own needs.

4.2.2 Basic supply data

The basic supply data are to be entered in the first block in the file.

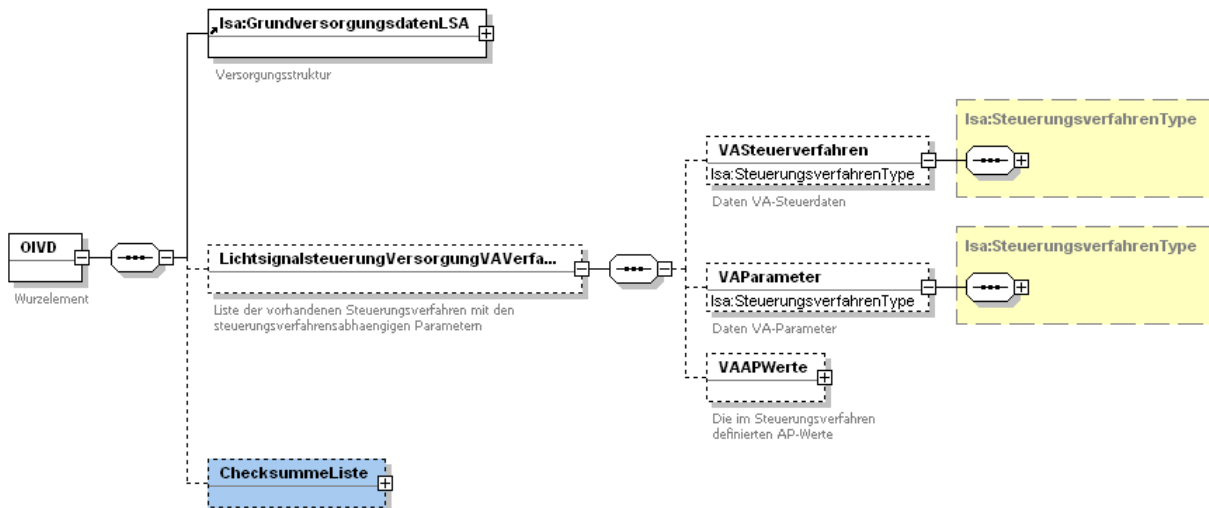

4.2.3 Control process

The traffic-related processes used by the traffic signal controller are to be separately entered in the file according to VASteuerverfahren and VAParameter. Currently, only one process is permitted with one parameter block.

The data supply for each TA control process or TA parameter appears as follows:

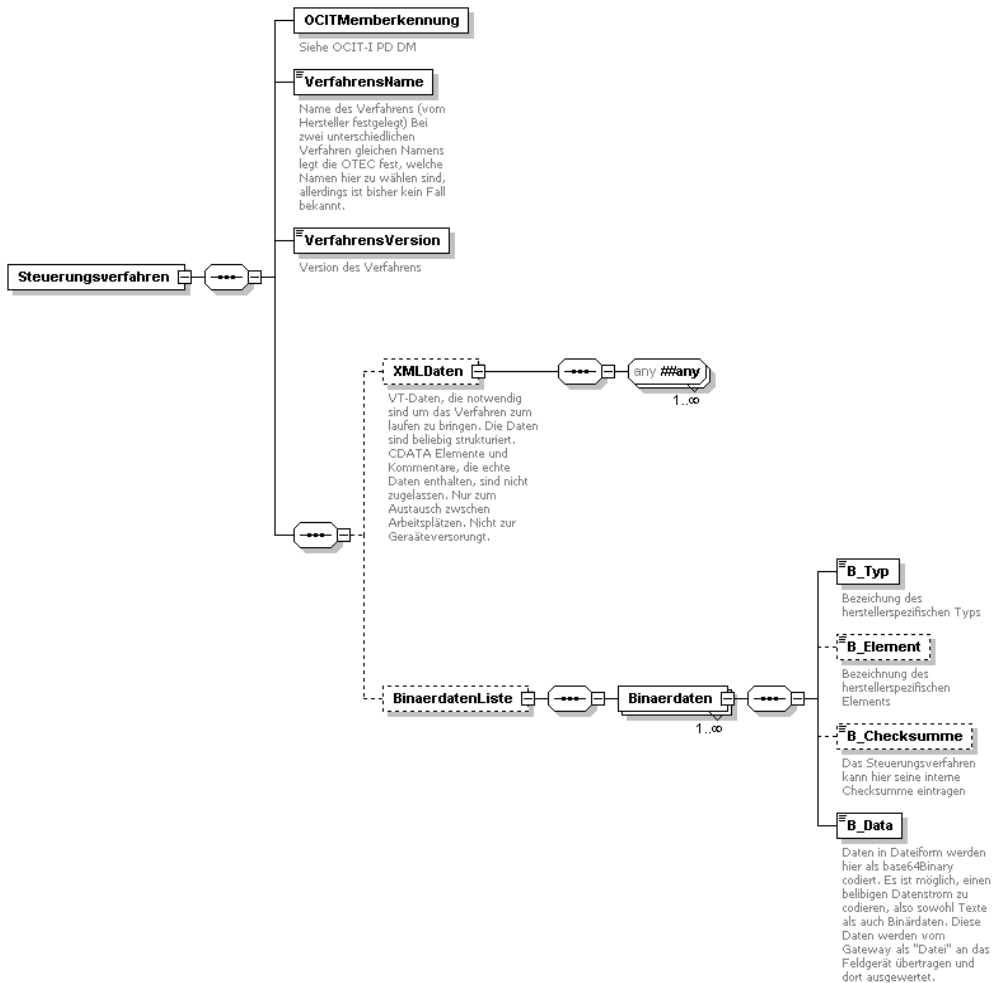

For each control process, the name and the version designation defined by the manufacturer is indicated. Additionally, it is possible to parametrize the control process. The format of parametrization for this is to be defined and announced by the manufacturer.

Here, the manufacturer of the control process can define what structure the parameters should have. The manufacturer has two basic options here:

- Processes that are parametrized via XML can store data as XML data. This dataset is not intended for the traffic signal controller but rather for exchange between planning stations. Any XML structure can be used, but it must adhere to the basic guidelines (no comments with attribute data, no CDATA elements, no macros with the exception of standard macros). Additionally, the manufacturer is obligated to include in delivery an XML schema for the XML structure.

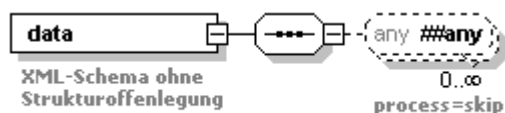

- For processes parametrized with files (non-XML text files or binary data), the process manufacturer can save the parametrization data as "binary data". In this format, any data flow will be encoded as base 64 and saved embedded in the XML structure. Because the base 64 format does not use any control characters from the XML structure, any data can be embedded. It is also permitted to divide the data into multiple binary files and attach these.

Additionally, there is also the option of verify the data of a TA process with a checksum and store it. This checksum can be found in the TA data area under user supply.

4.2.4 Restrictions

The following restrictions pose no problems for exporting and make it easier to create over-arching files that can be read by more than one tool.

- The elements of the frame not marked in colour are strictly obligatory. The order of the attributes—as strictly required in XML—is irrelevant. Indenting the elements, as in the example, is allowed but not necessary.
- XML comments can indeed be written but must not contain any relevant data and can be deleted at any time by any data supply tool.
- The only permitted macros are the five standard macros:

&	for the character	&
<	for the character	<
>	for the character	>
"	for the character	“
'	for the character	’

- CDATA sections are not permitted (note: CDATA are elements included in `<![CDATA[` and in `]]>` and may have any format).

4.3 Metadata of the AP values

4.3.1 Data catalog of the AP values of a control process

4.3.1.1 Identification

An identification string is used to identify AP values in the data model and in the **protocol** of the process data. The string is defined by the supplier of the control process. The string can start with the supplier's member number, e.g. 57.1. The member number is defined on the website <https://www.ocit.org> .

4.3.1.2 Schema of definitions of AP values

The definition of AP values follows the schema file *intersection_config_data_ap_values.xsd*.

The schema is needed

- to define new AP values
- to be able to validate automatically read AP value files in an application.

This schema is structured as explained in the following.

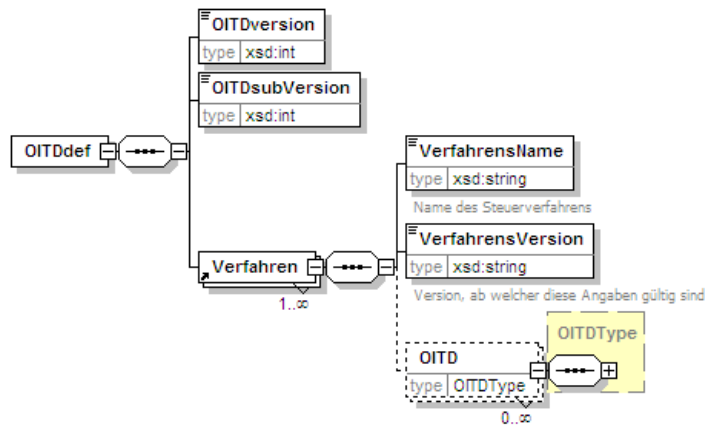

The root is the tag **<OITDdef>**, directly after this is the version information **<OITDVersion>** and subversion **<OITDSubVersion>** of the definitions in the relevant XML file (starting with the values 1 and 0 for version 1.0).

The following is the list of the processes **<Verfahren>** for which definitions are made. Every process is identified by its name **<VerfahrensName>**. Moreover, the version number of the process **<VerfahrensVersion>** as of which the definitions are valid is indicated. Definitions for various control processes, companies or organizations can be differentiated with processes.

For each process there follows the list of the AP value definitions **<OITD>**.

Every **<OITD>** entry describes a data type. It is identified by **<KurzBez>** and has a plain-text name **<Name>**.

To be displayed in user interfaces or documentation, the identifiers **<KurzBez>** or **<LangBez>** can be given under the tag **<Bezeichner>**. The short name is used as an identification string for data retrieval. The short name can begin with the member number.

Under the tag **<Beschreibung>** there can be a plain-text description of the data type that should be used for a more exact explanation or definition of the desired value.

Under the tag **<ODGref>** there can be a reference to an existing ODG data type (OCIT Outstations) that is identified by **<Member>** and **<OType>**; indicating **<BasetypeName>** is optional. Under the tag **<GrenzenWert>** there can be the minimum **<Min>**, maximum **<Max>** and a zero value **<NULL>** for the data type. Usually the highest possible value that can be shown is used as the zero value. The maximum value, therefore, is one value below that.

Under the tag **<GrenzenIndex>**, there can be the limits **<IndexMin>** and **<IndexMax>** that limit the value range of the object number for the data type.

The tag **<Interpretation>** is used to determine the interpretation of the data type's content. Here, under **<Aufloesung>**, the unit **<AufINum>** and the scale **<AufIEinheit>** can be indicated.

Under **<Enum>**, if the data type is a list type, the list of possible values **<Wert>** (these should always be whole numbers; the number 0 should not be used) and their textual representation **<Text>** can be accepted.

Under **<Darstellung>** [veraltet]³, you can find information on the visual display of the data type (e.g. in a user interface) similarly to the WTT agreement⁴.

Under **<AnfoLegacy>** [veraltet]⁵, info can be indicated with reference to the WTT code and model number for the locating a data value in the source system.

Finally, the association of the data type to any user defined groups **<OITDgruppe>** can be supplied in order to make it possible for applications to automatically have various visibilities.

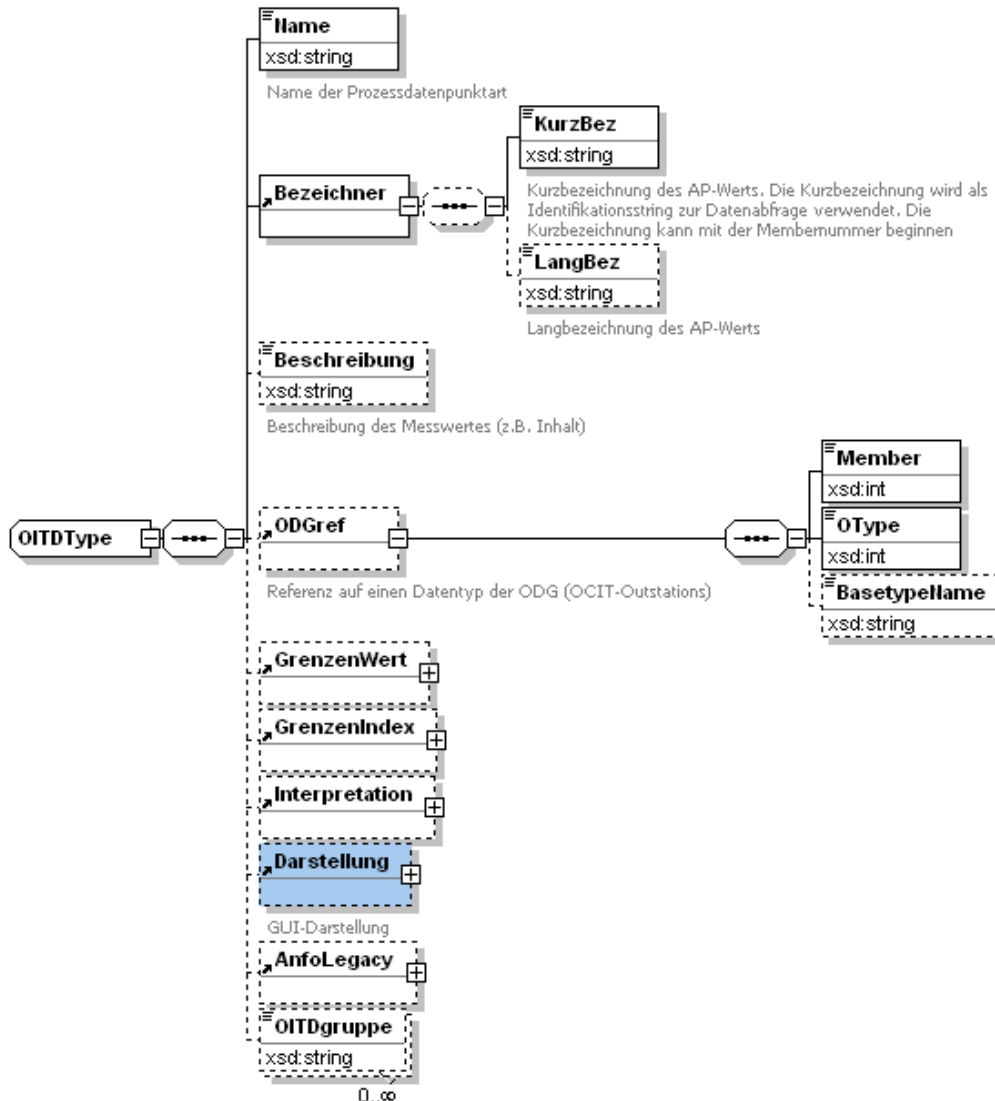

4.3.2 Data catalog of the AP values of an intersection

The AP values defined in the control process are listed under **<VAAPWerte>**. The definition is based on the data catalog of the AP values of a control process. This should make it

³ Can be omitted as it is obsolete.

⁴ WTT is an older trilateral agreement between PTV, Siemens and Verkehrs-Systeme AG.

⁵ Can be omitted as it is obsolete.

possible to address the relevant AP values without detailed knowledge of the control process and order them as process data.

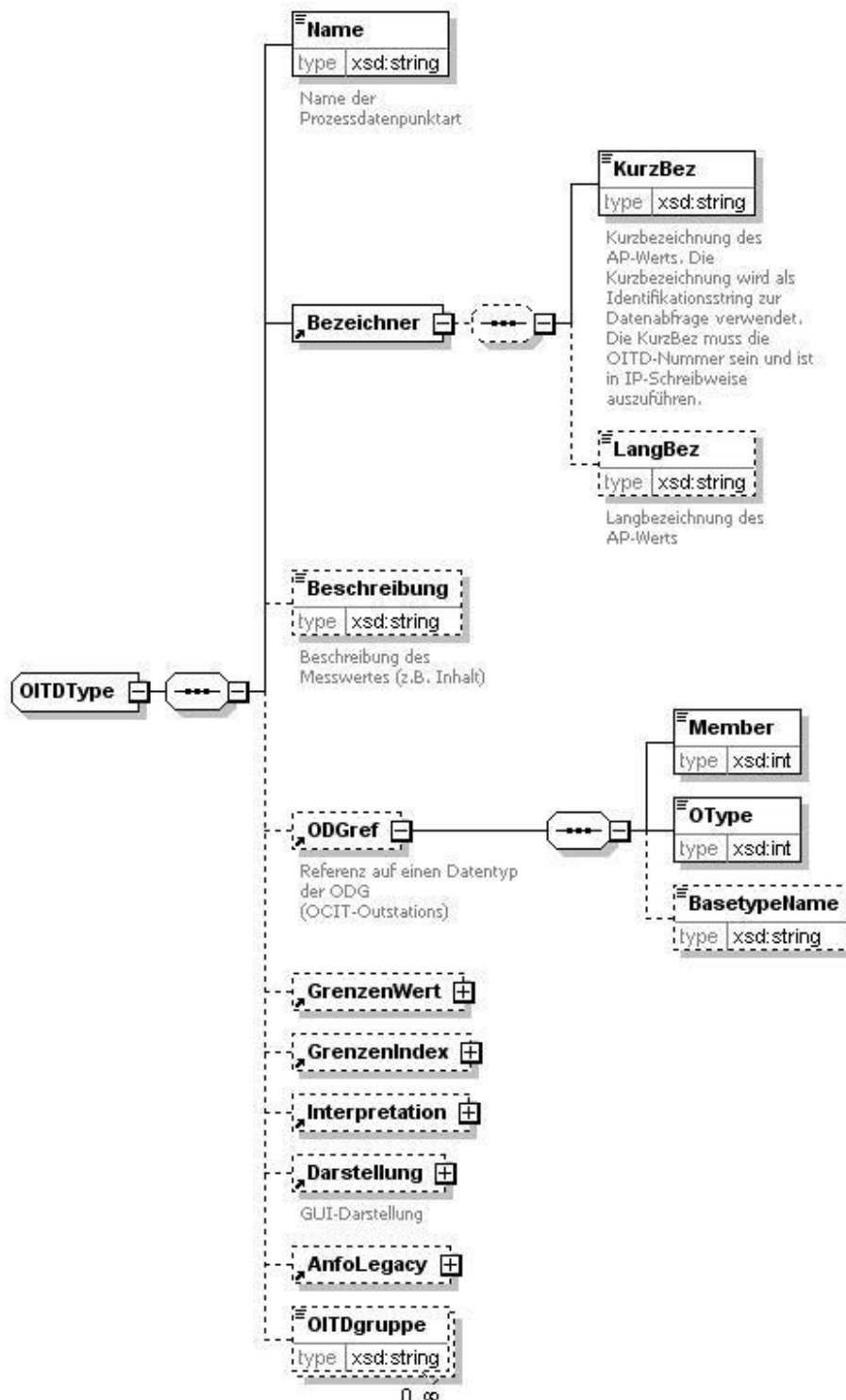

The short name is used as an identification string for data retrieval. The short name can begin with the member number.

4.4 Block formation

4.4.1 Standard blockformation

In the following overview, it is shown what data are summarized by default to what blocks in the sense of version assignment and checksum calculation.

4.4.1.1 Part A: User supply:

Traffic control system

Block 1: Basic Traffic Engineering Data/Fixed time:

- Switch-on programs (Einschaltprogramm under SignalprogrammListe)
- Switch-off programs (Ausschaltprogramm under SignalprogrammListe)
- Signal programs, data and green times (Signalprogramm under SignalprogrammListe)
- List of partial intersections
- List of traffic-related minimum green times (TRMindestfreigabe)
- List of traffic-related minimum red times (TRMindestgesperrt)
- Traffic-related IGT matrices (IntergreenTimeMatrix under IntergreenTimeMatrixList)
- Traffic-related offset time matrices (OffsetTimeMatrix under OffsetTimeMatrixList)
- Traffic-related minimum green times (TRMindestfreigabe)
- Traffic-related minimum red times (TRMindestgesperrt)

Block 2: Data with network reference:

- Header data (header data)
- 12 month automatic routine (control clock)

Block 3: TA control process:

- Application-specific files

Block 4: TA parameters:

- Application-specific files

Block 5: MAP supply

- contains the intersection's topology data (these data are only transmitted as a data block of data from ETSI (ASN.1 Format))

4.4.1.2 Part B: Manufacturer supply:

Controller system

- Detectors or digital inputs (EingangListe)
- Signal groups or digital outputs (SignalgruppenListe, DigitalerAusgangListe)
- Assignment to the partial intersection (AbschaltTeilknoten under Signalgruppe)
- Transition times (Zeitdauer, suspended under Uebergangselement)
- Definitions of reporting points (reporting point suspended under PTReportingSection and RPValues under PTMemoryInstance)

- Behavior during power outage (PowerOutage)

Safety system:

- Incompatibility matrix (Unvertraeglichkeitsmatrix)
- Safety-related intergreen time matrix (SicherheitsrelevanteZwischenzeitenmatrix)
- Minimum green times (Mindestfreigabe under SignalGruppe)
- Minimum red times (Mindestgesperrt under SignalGruppe)

4.4.1.3 Part C: NOCIT Data

NOCIT Data:

- Non-standardized planning data

Using the XML file *intersection_config_data_block_assignment.xml* it can be derived what data are assigned to what block and therefore through which of the checksums they are saved.

Changes to the block formation (as part of the new version of the interface) lead to changes in the controllers already supplied with data.

The XML file is described by the *intersection_config_data_block_assignment.xsd*:

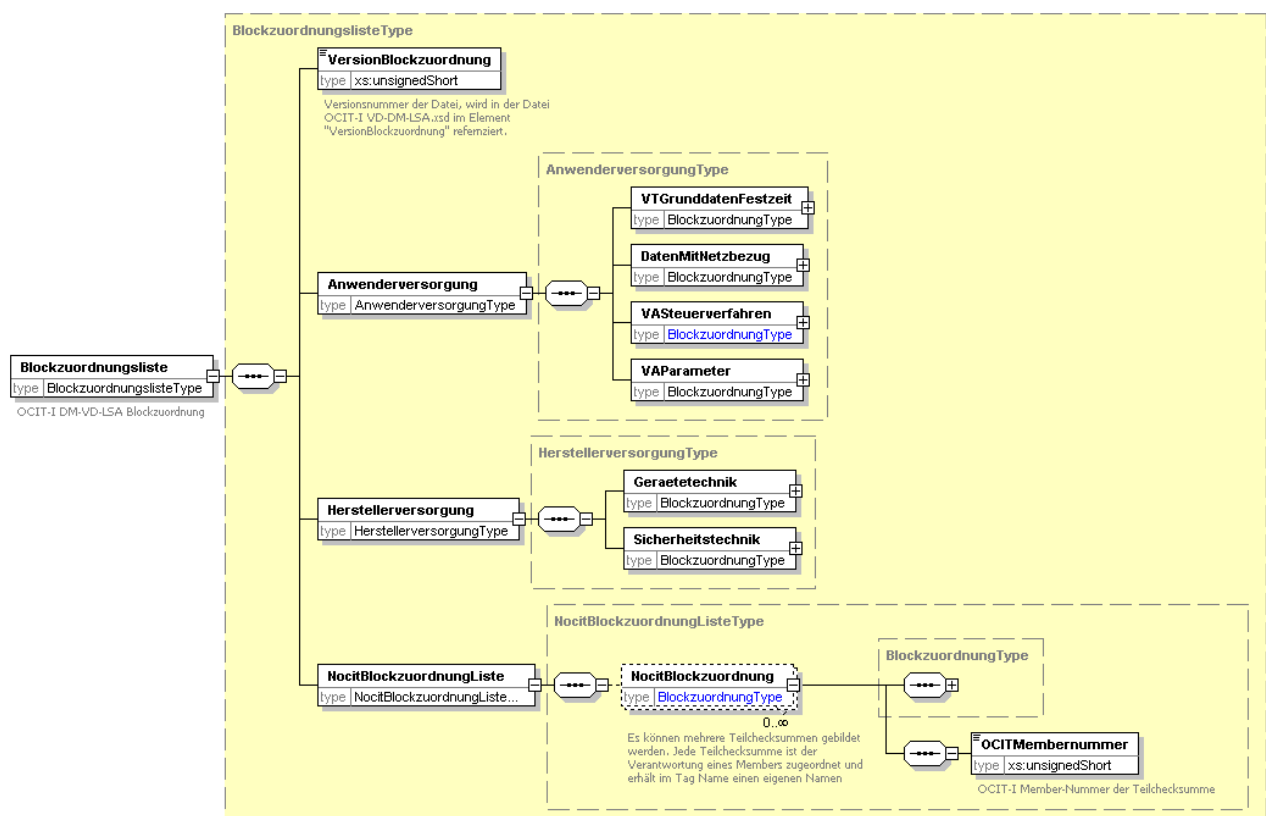

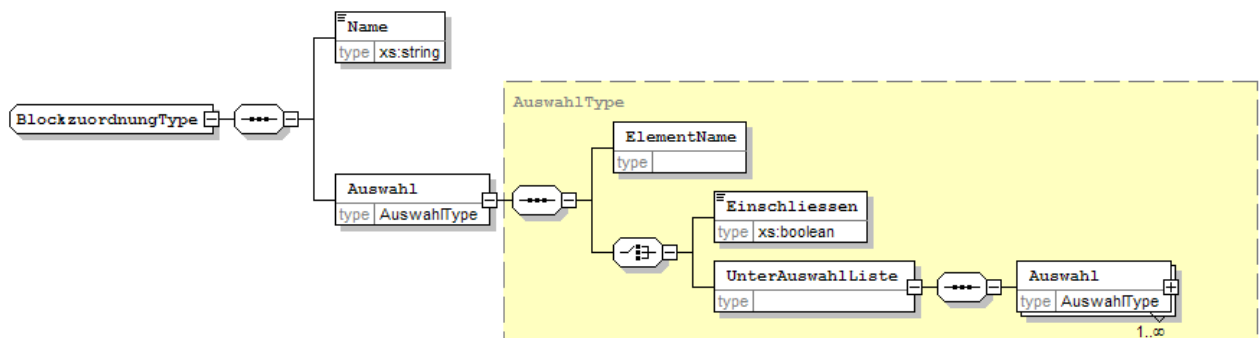

The type "AuswahlType" can contain itself iteratively. Details can be found in the XML schema file.

4.5 Checksums

With the CRC process for automatically calculating a checksum, a unique checksum is calculated over all the **traffic-related data**, that is, for example without the date, user, tool manufacturer of the planning tool. As long as the traffic-related supply data of the blocks do not change, the same checksum is created regardless of the program run. If, for example, in one configuration file of version A a green time is changed (version B) and then changed back (version C), then version A and C have the same checksum.⁶

Each checksum is created at least using each of the four established blocks of the traffic technology area. Furthermore, a checklist is created using the overall file. This also protects the otherwise not specifically protected data from the areas "Controller technology" and "Safety technology". Other checksums, e.g. with the inclusion of remark and comment fields, are possible. See XML file block.

The checksum from the NocitBlockzuordnung block is not adopted.

The checksums are listed under <ChecksummeListe>. The date is optional. At the latest during the data supply process of a ready file, the date however strictly must be filled in.

⁶ This requires the version number not to be part of the checksum calculation. In block assignment, it is therefore to be ensured that checksums that only included the content-based parts of the data supply are created.

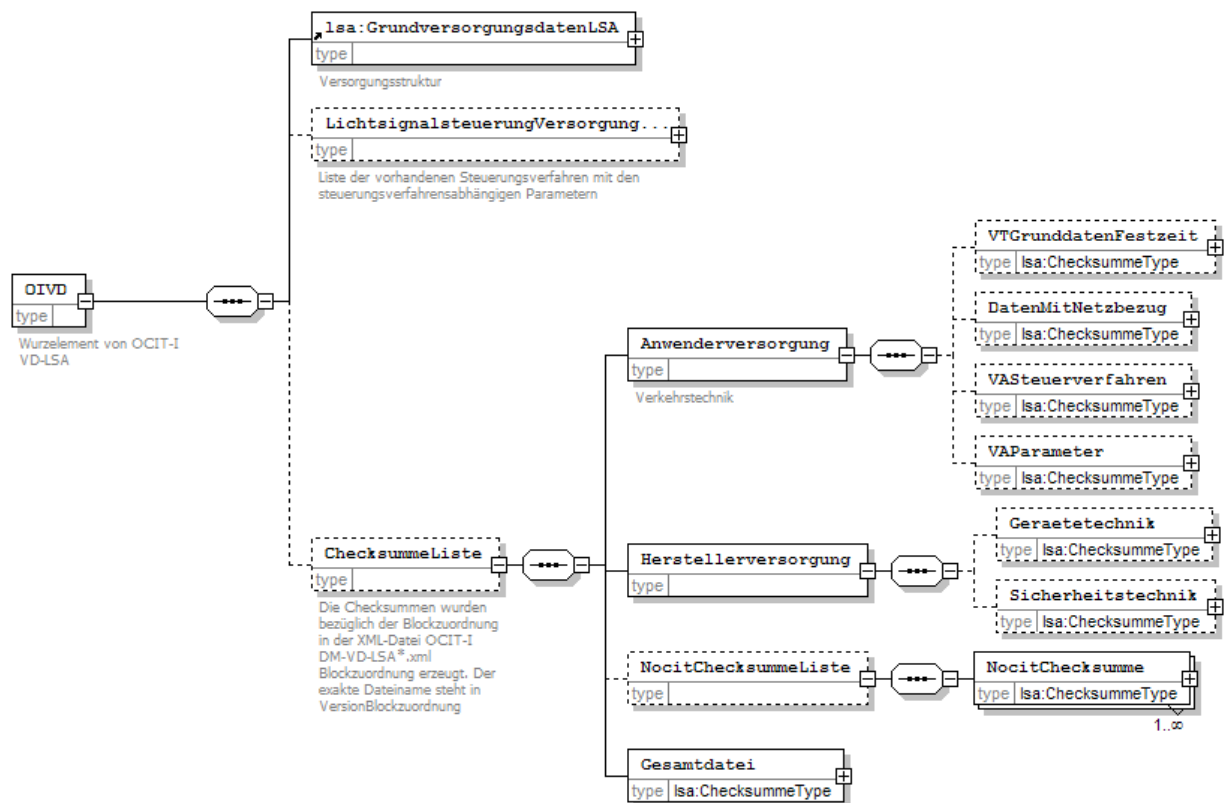

4.5.1 Process in the controller

The checksum information of the planning tool is sent via the server to the controller and stored there. In the controller, these data are not changed. The controller calculates its own checksums and its own build IDs that can be transferred via the communication protocol as per *intersection_config_data_communication.xsd*.

Whereas the checksum information of the planning tool is sent from the server to the controller and can then be read out from it, in the event of a local change in the controller the build ID, the checksum and the ID of the local change to the controller are only read by the server. A change is identified here as a local change if the FQDN of the other tool is not the FQDN of the control center.

The above-shown method gives a management tool all the options for analyzing both the changes to as well as the receipt of the actual traffic-related data.

The build ID is a simple counter in the traffic signal controller that is incremented for each the data supply operation, regardless of whether it is central or local. Additionally, a checksum with the data is calculated in the controller. From the pair calculated from the build number and the checksum it can be uniquely identified whether data have been modified or match the known version. The build number and the checksum can be read out from the controller. If modified controller build numbers and checksums are identified, it is sure that someone modified parameters on site. In this case, the data can be uploaded or the local changes must also be made in the planning tool if it is there that the main management of the planning data takes place.

4.5.2 Structure and depiction of the checksums

Any number of checksums is possible for each configuration file, at least one per block and another for the overall file. These checksums can be created by any planning tool. A checksum contains only a subset of the data within the file. All data not included by the checksum can be changed without infringing upon the checksum.

Writing a checksum follows the structure below:

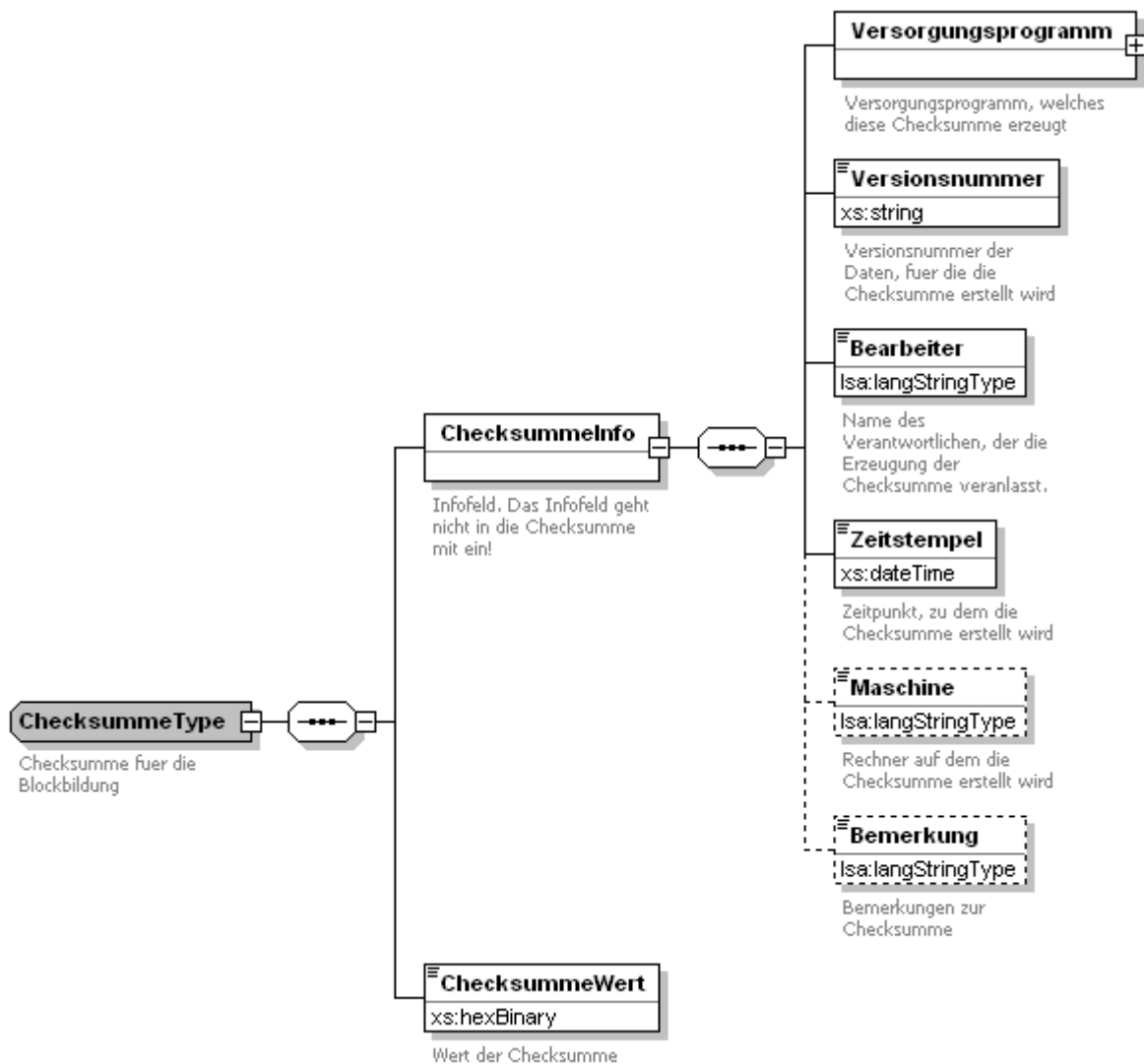

In **ChecksumInfo**, the user-specific data that (can) appear on the interface are saved. These are:

- the data supply program with which the checksum was generated. The data supply program consists of a name and version.
- the version number of the dataset for which the checksum was generated. The data supply program assign a version to a dataset. The version number corresponds to the item <VersionsnummerOCIT-I> in the communication protocol as per *intersection_config_data_communication.xsd*.
- the user who prompted the checklist to be generated
- the timestamp of the time at which the checksum was generated
- the timestamp of the time at which the checksum was generated. Entry is optional.
- comment

The item <ChecksummeWert> is encoded in hexadecimal. It corresponds to the item <ChecksummeOCIT-I> in the communication protocol as per *intersection_config_data_communication.xsd*.

Note: For reasons of legibility, it should be displayed in 10 groups of 2 bytes each:
 e.g. CAFE-1234-ABCD-5678-A1B2-C3D4-1A1B-1234-CAFE-ABBA.

4.5.3 Checksum algorithm

Like in the OCIT-O log, the SHA-1 algorithm is used to calculate the checksum. You can find further information in the document OCIT-O log, chapter Transfer monitoring by the SHA-1 algorithm and in the document OCIT-O TSC V3.0, chapter Standard process for checksum calculation. Code samples are also listed here.

To calculate a unique checksum the data must be standardized. For this the data types must be defined (see table) and the data sorted. The data are provided XML tags. However, there must not be any indentations (tabs), spaces or lines between the tags. The tags are written in order and with the <ElementName> from the block assignment *intersection_config_data_block_assignment.xml*.

For sorting, all the elements derived from the OCIT ObjektHeader are sorted in ascending order according to the short designation and according to length. Elements not derived from the OCIT ObjektHeader are sorted according to the first non-optional element. As such, signal program lines <SPZeile> are sorted in ascending order according to <SignalGruppe> and their switching times <Schaltzeit> according to the <Schaltzeitpunkt>.

Definition of the data types:

Data type	Data for the checksums
langStringType kurzStringType bezeichnungType	String based on "xs:string" is used with UTF8 encoding like in the XML
Sekunde FestzeitplanSekunde VZSekunde	Times in decimal format based on "xs:decimal" There is always one decimal place written, e.g. "0.0" (-)[0-9]+.[0-9]
OCITSignalbild	The signal patterns are written in code. [0-9A-F][0-9A-F]
Whole number (xs:int, xs:unsignedInt; xs:short ...)	Whole number, negative too. Without leading zeros. Only negative sign. (-)[0-9]+
xs:datetime	Date and time as ISO date without time zone CCYY-MM-DDThh:mm:ss
xs:date	Date without time as ISO date CCYY-MM-DD
xs:gMonthDay	Date with month and day without year --MM-DD
xs:time	Time with leading zero hh:mm:ss

Condensed example about the data used in the checksum algorithms (spaces inserted between the tags for clarity):

```
<OIVD> <GrundversorgungsdatenLSA> <DateiVersion> <VersionDokument>01.13.00</...>
</DateiVersion> <SignalprogrammListe> <Signalprogramm>
```

<BezeichnungKurz>SP1_22_OK</...> <SPZeile> <Signalgruppe>SG 1</Signalgruppe>
<Schaltzeit> <Schaltzeitpunkt>1.0</Schaltzeitpunkt> <Signalbild>30</Signalbild>
</Schaltzeit> </SPZeile> </Signalprogramm> <...> </SignalprogrammListe> <...>
</GrundversorgungsdatenLSA> </OIVD>

5 Communication log

The XML file from the TSS data supply information from the schema *intersection_config_data.xsd* can be exchanged manually, e.g. via a file system, or transferred automatically with the communication protocol from the *intersection_config_data_communication.xsd*. The communication protocol is based on mechanisms in OCIT-C and is a part of *intersection_config_data_communication.xsd*.

Methods, objects and submission parameters used:

Method + Object type	Request / Response
Get + SupplyDataInfo	Request: <i>GetType.data.SupplyDataInfoType</i>
	Response: <i>GetResponseType.DataList.Ds.data.SupplyDataInfoResponseType</i>
Put + SupplyData_putSupplyData	Request: <i>PutType.PutType.PutList.Putds.data.putSupplyDataType</i>
	Response: <i>PutResponseType.data.putSupplyDataResponseType</i>
Put + SupplyData_activateSupplyData	Request: <i>PutType.PutType.PutList.Putds.data.activateSupplyDataType</i>
	Response: <i>PutResponseType.data.activateSupplyDataResponseType</i>
Put + SupplyData_putandactivateSupplyData	Request: <i>PutType.PutType.PutList.Putds.data.putAndActivateSupplyDataType</i>
	Response: <i>PutResponseType.data.putAndActivateSupplyDataResponseType</i>
Put + SupplyData_resetSupplyData	Request: <i>PutType.PutType.PutList.Putds.data.resetSupplyDataType</i>
	Response: <i>PutResponseType.data.resetSupplyDataResponseType</i>
Get + SupplyData_getSupplyData	Request: <i>GetType.data.getSupplyDataType</i>
	Response: <i>GetResponseType.DataList.Ds.data.getSupplyDataResponseType</i>
Get + SupplyDataInfoList	Request: <i>GetType.data.SupplyDataInfoListType</i>
	Response: <i>GetResponseType.DataList.Ds.data.SupplyDataInfoListResponseType</i>

Get + S upplyUnitList	Request: <i>GetType.data.SupplyUnitListType</i>
	Response: <i>GetResponseType.DataList.Ds.data.SupplyUnitListResponseType</i>

The optional element "data" (type any) from the protocol definition is used to transfer the parameters needed for the supply data.

Recommended identification:

J<primary key>

The <primary key> has the following structure:

<SystemNr>_<SubsystemNr>_<UnitNr>_<ObjektNr>

Optional:

SystemNr, SubsystemNr, ObjektNr (if complete object is addressed)

Note: The identifiers SystemNr, SubsystemNr, UnitNr and ObjektNr have been taken from the OCIT-I standard.

The assignment of the position number in the log has no function because there is no history. The value should be assigned 0.

6 Terms and abbreviations

Term / abbreviation	Description
AP	User program
Client	A program which wishes to use services offered by other (servers) and actively opens them to do so.
DATEX II	Specifications of Technical Committee 278 of the European Committee for Standardization (CEN) for the exchange of traffic-related data between traffic control centers.
DM	Data Model and objects
FTP	File Transfer Protocol, a network protocol for transferring files
http	HyperText Transfer Protocol, a protocol for transferring data over a network.
ISO	International Organization for Standardization
IND	Individual traffic
TSS	Traffic signal system
Method	The algorithms assigned to a class of objects. Also used as a synonym for function, procedure, command, action.
OCA	Open Traffic City Association
OCIT	Open Communication Interface for Road Traffic Control Systems / Offene Schnittstellen für die Straßenverkehrstechnik.
OCIT-C	Open Communication Interface for Road Traffic Control Systems - Center to Center. OCIT-C covers the functions for communicating between the central traffic control and traffic guidance systems.
OCIT-O	OCIT Outstations Interface between traffic control centres and traffic signal controllers for controlling and supplying the traffic signal controllers.
ODG	OCIT Developer Group
OITD	OCIT-Instations Traffic Data
OSI	Open Systems Interconnection Reference Model, a communication model of the International Organization for Standardization (ISO) for communication protocols in computer networks.
PT	Public transport

PD	Process data
Protocolmanager	Protocol layer used for implementing commands in the buffer
Server	A program that offers certain services and passively waits on incoming calls (from clients) to do so.
SGR	Signal group
SOAP	SOAP (Simple Object Access Protocol), a protocol which enables data to be exchanged between systems. SOAP uses the "Remote Procedure Call", through which it enables the functions in other computers to be called. See http://www.w3.org/TR/SOAP
Soap-Client-Interface	Soap and Protocolmanager on the client side
Soap-Server-Interface	Soap and Protocolmanager on the server side
SP	Interfaces and Protocols
SSL	Secure Socket Layer.
TCP / IP	Transmission Control Protocol/Internet Protocol, a family of network protocols for the Internet.
TLS	Technical delivery terms for roadway stations. The TLS are a standard for the structure of traffic control systems on major German Federal highways. Issued by: German Federal Highway Research Institute
TU	Cycle time
URL	Uniform Resource Locator
UTC	Coordinated Universal Time
TA	Traffic actuation
VD	Supply data
VDV	Verband Deutscher Verkehrsunternehmen (Association of German Transportation Companies)
WSDL	Web Services Description Language, a platform/programme language and protocol-independent description language for network services (web services) for exchanging messages based on XML.
XML	Extensible Markup Language, a markup language for presenting structured data in the form of text. XML is used among other things for a platform and implementation-independent exchange of data between computer systems. An XML document is made up of text characters, in the most basic case in ASCII coding, and is therefore machine-readable. It does not contain binary data. The XML specification is published by the World Wide Web Consortium (W3C) as a recommendation.

XSD	XML schema, a recommendation of the World Wide Web Consortium (W3C) for defining structures for XML documents. The structure is described in the form of an XML document. Furthermore, it supports a large number of data types. The XSD schema language describes data types, individual XML schema instances (documents) and groups of such instances. A specific XML schema is called an XSD (XML Schema Definition) and the file usually has the ending ".xsd".
-----	---

Further explanations about the technical terms and abbreviations used in this document can be found in "OCIT – O Glossary V3.0".

Appendix 1: Bit code of the signal patterns

Complete table of the signal patterns

Name	Description	Value
dunkel	dunkel	0
roT1Hz	rot_blinken_start_dunkel 1Hz	1
ROt1Hz	rot_blinken_start_hell 1Hz	2
rot	rot	3
geLB1Hz	gelb_blinken_start_dunkel 1Hz	4
roTgeLB1Hz	rot_blinken_start_dunkel gelb_blinken_start_dunkel 1Hz	5
ROtgeLB1Hz	rot_blinken_start_hell gelb_blinken_start_dunkel 1Hz	6
rotgeLB1Hz	rot gelb_blinken_start_dunkel 1Hz	7
GEIb1Hz	gelb_blinken_start_hell 1Hz	8
roTGEIb1Hz	rot_blinken_start_dunkel gelb_blinken_start_hell 1Hz	9
ROtGEIb1Hz	rot_blinken_start_hell gelb_blinken_start_hell 1Hz	10
rotGEIb1Hz	rot gelb_blinken_start_hell 1Hz	11
gelb	gelb	12
roTgelb1Hz	rot_blinken_start_dunkel gelb 1Hz	13
ROtgelb1Hz	rot_blinken_start_hell gelb 1Hz	14
rotgelb	rot gelb	15
grUEN1Hz	gruen_blinken_start_dunkel 1Hz	16
roTgrUEN1Hz	rot_blinken_start_dunkel gruen_blinken_start_dunkel 1Hz	17
ROtgrUEN1Hz	rot_blinken_start_hell gruen_blinken_start_dunkel 1Hz	18
rotgrUEN1Hz	rot gruen_blinken_start_dunkel 1Hz	19
geLBgrUEN1Hz	gelb_blinken_start_dunkel gruen_blinken_start_dunkel 1Hz	20
roT-geLBgrUEN1Hz	rot_blinken_start_dunkel gelb_blinken_start_dunkel gruen_blinken_start_dunkel 1Hz	21

ROt-geLBgrUEN1Hz	rot_blinken_start_hell gelb_blinken_start_dunkel gruen_blinken_start_dunkel 1Hz	22
rot-geLBgrUEN1Hz	rot gelb_blinken_start_dunkel gruen_blinken_start_dunkel 1Hz	23
GEIbgrUEN1Hz	gelb_blinken_start_hell gruen_blinken_start_dunkel 1Hz	24
roT-GEIbgrUEN1Hz	rot_blinken_start_dunkel gelb_blinken_start_hell gruen_blinken_start_dunkel 1Hz	25
ROt-GEIbgrUEN1Hz	rot_blinken_start_hell gelb_blinken_start_hell gruen_blinken_start_dunkel 1Hz	26
rot-GEIbgrUEN1Hz	rot gelb_blinken_start_hell gruen_blinken_start_dun- kel 1Hz	27
gelbgrUEN1Hz	gelb gruen_blinken_start_dunkel 1Hz	28
roT-gelbgrUEN1Hz	rot_blinken_start_dunkel gelb gruen_blinken_start_dunkel 1Hz	29
ROt-gelbgrUEN1Hz	rot_blinken_start_hell gelb gruen_blinken_start_dun- kel 1Hz	30
rot-gelbgrUEN1Hz	rot gelb gruen_blinken_start_dunkel 1Hz	31
GRuen1Hz	gruen_blinken_start_hell 1Hz	32
roTGRuen1Hz	rot_blinken_start_dunkel gruen_blinken_start_hell 1Hz	33
ROtGRuen1Hz	rot_blinken_start_hell gruen_blinken_start_hell 1Hz	34
rotGRuen1Hz	rot gruen_blinken_start_hell 1Hz	35
geLBGRuen1Hz	gelb_blinken_start_dunkel gruen_blinken_start_hell 1Hz	36
roT-geLBGRuen1Hz	rot_blinken_start_dunkel gelb_blinken_start_dunkel gruen_blinken_start_hell 1Hz	37
ROt-geLBGRuen1Hz	rot_blinken_start_hell gelb_blinken_start_dunkel gruen_blinken_start_hell 1Hz	38
rot-geLBGRuen1Hz	rot gelb_blinken_start_dunkel gruen_blinken_start_hell 1Hz	39
GEIbGRuen1Hz	gelb_blinken_start_hell gruen_blinken_start_hell 1Hz	40
roT-GEIbGRuen1Hz	rot_blinken_start_dunkel gelb_blinken_start_hell gruen_blinken_start_hell 1Hz	41

ROt-GEIbGRuen1Hz	rot_blinken_start_hell gelb_blinken_start_hell gruen_blinken_start_hell 1Hz	42
rot-GEIbGRuen1Hz	rot gelb_blinken_start_hell gruen_blinken_start_hell 1Hz	43
gelbGRuen1Hz	gelb gruen_blinken_start_hell 1Hz	44
roT-gelbGRuen1Hz	rot_blinken_start_dunkel gelb gruen_blinken_start_hell 1Hz	45
ROt-gelbGRuen1Hz	rot_blinken_start_hell gelb gruen_blinken_start_hell 1Hz	46
rot-gelbGRuen1Hz	rot gelb gruen_blinken_start_hell 1Hz	47
gruen	gruen	48
roTgruen1Hz	rot_blinken_start_dunkel gruen 1Hz	49
ROtgruen1Hz	rot_blinken_start_hell gruen 1Hz	50
rotgruen	rot gruen	51
geLBgruen1Hz	gelb_blinken_start_dunkel gruen 1Hz	52
roT-geLBgruen1Hz	rot_blinken_start_dunkel gelb_blinken_start_dunkel gruen 1Hz	53
ROt-geLBgruen1Hz	rot_blinken_start_hell gelb_blinken_start_dunkel gruen 1Hz	54
rot-geLBgruen1Hz	rot gelb_blinken_start_dunkel gruen 1Hz	55
GEIbgruen1Hz	gelb_blinken_start_hell gruen 1Hz	56
roT-GEIbgruen1Hz	rot_blinken_start_dunkel gelb_blinken_start_hell gruen 1Hz	57
ROt-GEIbgruen1Hz	rot_blinken_start_hell gelb_blinken_start_hell gruen 1Hz	58
rot-GEIbgruen1Hz	rot gelb_blinken_start_hell gruen 1Hz	59
gelbgruen	gelb gruen	60
roT-gelbgruen1Hz	rot_blinken_start_dunkel gelb gruen 1Hz	61
ROt-gelbgruen1Hz	rot_blinken_start_hell gelb gruen 1Hz	62

rotgelbgruen	rot gelb gruen	63
dunkel2Hz	dunkel 2Hz	64
roT2Hz	rot_blinken_start_dunkel 2Hz	65
ROt2Hz	rot_blinken_start_hell 2Hz	66
rot2Hz	rot 2Hz	67
geLB2Hz	gelb_blinken_start_dunkel 2Hz	68
roTgeLB2Hz	rot_blinken_start_dunkel gelb_blinken_start_dunkel 2Hz	69
ROtgeLB2Hz	rot_blinken_start_hell gelb_blinken_start_dunkel 2Hz	70
rotgeLB2Hz	rot gelb_blinken_start_dunkel 2Hz	71
GEIb2Hz	gelb_blinken_start_hell 2Hz	72
roTGEIb2Hz	rot_blinken_start_dunkel gelb_blinken_start_hell 2Hz	73
ROtGEIb2Hz	rot_blinken_start_hell gelb_blinken_start_hell 2Hz	74
rotGEIb2Hz	rot gelb_blinken_start_hell 2Hz	75
gelb2Hz	gelb 2Hz	76
roTgelb2Hz	rot_blinken_start_dunkel gelb 2Hz	77
ROtgelb2Hz	rot_blinken_start_hell gelb 2Hz	78
rotgelb2Hz	rot gelb 2Hz	79
grUEN2Hz	gruen_blinken_start_dunkel 2Hz	80
roTgrUEN2Hz	rot_blinken_start_dunkel gruen_blinken_start_dunkel 2Hz	81
ROtgrUEN2Hz	rot_blinken_start_hell gruen_blinken_start_dunkel 2Hz	82
rotgrUEN2Hz	rot gruen_blinken_start_dunkel 2Hz	83
geLBgrUEN2Hz	gelb_blinken_start_dunkel gruen_blinken_start_dunkel 2Hz	84
roT-geLBgrUEN2Hz	rot_blinken_start_dunkel gelb_blinken_start_dunkel gruen_blinken_start_dunkel 2Hz	85
ROt-geLBgrUEN2Hz	rot_blinken_start_hell gelb_blinken_start_dunkel gruen_blinken_start_dunkel 2Hz	86

rot-geLBgrUEN2Hz	rot gelb_blinken_start_dunkel gruen_blinken_start_dunkel 2Hz	87
GEIbgrUEN2Hz	gelb_blinken_start_hell gruen_blinken_start_dunkel 2Hz	88
roT-GEIbgrUEN2Hz	rot_blinken_start_dunkel gelb_blinken_start_hell gruen_blinken_start_dunkel 2Hz	89
ROt-GEIbgrUEN2Hz	rot_blinken_start_hell gelb_blinken_start_hell gruen_blinken_start_dunkel 2Hz	90
rot-GEIbgrUEN2Hz	rot gelb_blinken_start_hell gruen_blinken_start_dun- kel 2Hz	91
gelbgrUEN2Hz	gelb gruen_blinken_start_dunkel 2Hz	92
roT-gelbgrUEN2Hz	rot_blinken_start_dunkel gelb gruen_blinken_start_dunkel 2Hz	93
ROt-gelbgrUEN2Hz	rot_blinken_start_hell gelb gruen_blinken_start_dun- kel 2Hz	94
rot-gelbgrUEN2Hz	rot gelb gruen_blinken_start_dunkel 2Hz	95
GRuen2Hz	gruen_blinken_start_hell 2Hz	96
roTGRuen2Hz	rot_blinken_start_dunkel gruen_blinken_start_hell 2Hz	97
ROtGRuen2Hz	rot_blinken_start_hell gruen_blinken_start_hell 2Hz	98
rotGRuen2Hz	rot gruen_blinken_start_hell 2Hz	99
geLBGRuen2Hz	gelb_blinken_start_dunkel gruen_blinken_start_hell 2Hz	100
roT-geLBGRuen2Hz	rot_blinken_start_dunkel gelb_blinken_start_dunkel gruen_blinken_start_hell 2Hz	101
ROt-geLBGRuen2Hz	rot_blinken_start_hell gelb_blinken_start_dunkel gruen_blinken_start_hell 2Hz	102
rot-geLBGRuen2Hz	rot gelb_blinken_start_dunkel gruen_blinken_start_hell 2Hz	103
GEIbGRuen2Hz	gelb_blinken_start_hell gruen_blinken_start_hell 2Hz	104
roT-GEIbGRuen2Hz	rot_blinken_start_dunkel gelb_blinken_start_hell gruen_blinken_start_hell 2Hz	105
ROt-GEIbGRuen2Hz	rot_blinken_start_hell gelb_blinken_start_hell gruen_blinken_start_hell 2Hz	106

rot- GEIbGRuen2Hz	rot gelb_blinken_start_hell gruen_blinken_start_hell 2Hz	107
gelbGRuen2Hz	gelb gruen_blinken_start_hell 2Hz	108
roT- gelbGRuen2Hz	rot_blinken_start_dunkel gelb gruen_blinken_start_hell 2Hz	109
ROt- gelbGRuen2Hz	rot_blinken_start_hell gelb gruen_blinken_start_hell 2Hz	110
rot- gelbGRuen2Hz	rot gelb gruen_blinken_start_hell 2Hz	111
gruen2Hz	gruen 2Hz	112
roTgruen2Hz	rot_blinken_start_dunkel gruen 2Hz	113
ROtgruen2Hz	rot_blinken_start_hell gruen 2Hz	114
rotgruen2Hz	rot gruen 2Hz	115
geLBgruen2Hz	gelb_blinken_start_dunkel gruen 2Hz	116
roT- geLBgruen2Hz	rot_blinken_start_dunkel gelb_blinken_start_dunkel gruen 2Hz	117
ROt- geLBgruen2Hz	rot_blinken_start_hell gelb_blinken_start_dunkel gruen 2Hz	118
rot- geLBgruen2Hz	rot gelb_blinken_start_dunkel gruen 2Hz	119
GEIbgruen2Hz	gelb_blinken_start_hell gruen 2Hz	120
roT- GEIbgruen2Hz	rot_blinken_start_dunkel gelb_blinken_start_hell gruen 2Hz	121
ROt- GEIbgruen2Hz	rot_blinken_start_hell gelb_blinken_start_hell gruen 2Hz	122
rot- GEIbgruen2Hz	rot gelb_blinken_start_hell gruen 2Hz	123
gelbgruen2Hz	gelb gruen 2Hz	124
roT- gelbgruen2Hz	rot_blinken_start_dunkel gelb gruen 2Hz	125
ROt- gelbgruen2Hz	rot_blinken_start_hell gelb gruen 2Hz	126
rotgelbgruen2Hz	rot gelb gruen 2Hz	127

dunkel1R	dunkel reserved_1	128
roT1R	rot_blinken_start_dunkel reserved_1	129
ROt1R	rot_blinken_start_hell reserved_1	130
rot1R	rot reserved_1	131
geLB1R	gelb_blinken_start_dunkel reserved_1	132
roTgeLB1R	rot_blinken_start_dunkel gelb_blinken_start_dunkel reserved_1	133
ROtgeLB1R	rot_blinken_start_hell gelb_blinken_start_dunkel reserved_1	134
rotgeLB1R	rot gelb_blinken_start_dunkel reserved_1	135
GEIb1R	gelb_blinken_start_hell reserved_1	136
roTGEIb1R	rot_blinken_start_dunkel gelb_blinken_start_hell reserved_1	137
ROtGEIb1R	rot_blinken_start_hell gelb_blinken_start_hell reserved_1	138
rotGEIb1R	rot gelb_blinken_start_hell reserved_1	139
gelb1R	gelb reserved_1	140
roTgelb1R	rot_blinken_start_dunkel gelb reserved_1	141
ROtgelb1R	rot_blinken_start_hell gelb reserved_1	142
rotgelb1R	rot gelb reserved_1	143
grUEN1R	gruen_blinken_start_dunkel reserved_1	144
roTgrUEN1R	rot_blinken_start_dunkel gruen_blinken_start_dunkel reserved_1	145
ROtgrUEN1R	rot_blinken_start_hell gruen_blinken_start_dunkel reserved_1	146
rotgrUEN1R	rot gruen_blinken_start_dunkel reserved_1	147
geLBgrUEN1R	gelb_blinken_start_dunkel gruen_blinken_start_dunkel reserved_1	148
roT-geLBgrUEN1R	rot_blinken_start_dunkel gelb_blinken_start_dunkel gruen_blinken_start_dunkel reserved_1	149
ROt-geLBgrUEN1R	rot_blinken_start_hell gelb_blinken_start_dunkel gruen_blinken_start_dunkel reserved_1	150

rot-geLBgrUEN1R	rot gelb_blinken_start_dunkel gruen_blinken_start_dunkel reserved_1	151
GEIbgrUEN1R	gelb_blinken_start_hell gruen_blinken_start_dunkel reserved_1	152
roT-GEIbgrUEN1R	rot_blinken_start_dunkel gelb_blinken_start_hell gruen_blinken_start_dunkel reserved_1	153
ROt-GEIbgrUEN1R	rot_blinken_start_hell gelb_blinken_start_hell gruen_blinken_start_dunkel reserved_1	154
rot-GEIbgrUEN1R	rot gelb_blinken_start_hell gruen_blinken_start_dun- kel reserved_1	155
gelbgrUEN1R	gelb gruen_blinken_start_dunkel reserved_1	156
roT-gelbgrUEN1R	rot_blinken_start_dunkel gelb gruen_blinken_start_dunkel reserved_1	157
ROt-gelbgrUEN1R	rot_blinken_start_hell gelb gruen_blinken_start_dun- kel reserved_1	158
rotgelbgrUEN1R	rot gelb gruen_blinken_start_dunkel reserved_1	159
GRuen1R	gruen_blinken_start_hell reserved_1	160
roTGRuen1R	rot_blinken_start_dunkel gruen_blinken_start_hell re- served_1	161
ROtGRuen1R	rot_blinken_start_hell gruen_blinken_start_hell re- served_1	162
rotGRuen1R	rot gruen_blinken_start_hell reserved_1	163
geLBGRuen1R	gelb_blinken_start_dunkel gruen_blinken_start_hell reserved_1	164
roT-geLBGRuen1R	rot_blinken_start_dunkel gelb_blinken_start_dunkel gruen_blinken_start_hell reserved_1	165
ROt-geLBGRuen1R	rot_blinken_start_hell gelb_blinken_start_dunkel gruen_blinken_start_hell reserved_1	166
rot-geLBGRuen1R	rot gelb_blinken_start_dunkel gruen_blinken_start_hell reserved_1	167
GEIbGRuen1R	gelb_blinken_start_hell gruen_blinken_start_hell re- served_1	168
roT-GEIbGRuen1R	rot_blinken_start_dunkel gelb_blinken_start_hell gruen_blinken_start_hell reserved_1	169

ROt-GEIbGRuen1R	rot_blinken_start_hell gelb_blinken_start_hell gruen_blinken_start_hell reserved_1	170
rot-GEIbGRuen1R	rot gelb_blinken_start_hell gruen_blinken_start_hell reserved_1	171
gelbGRuen1R	gelb gruen_blinken_start_hell reserved_1	172
roT-gelbGRuen1R	rot_blinken_start_dunkel gelb gruen_blinken_start_hell reserved_1	173
ROt-gelbGRuen1R	rot_blinken_start_hell gelb gruen_blinken_start_hell reserved_1	174
rotgelbGRuen1R	rot gelb gruen_blinken_start_hell reserved_1	175
gruen1R	gruen reserved_1	176
roTgruen1R	rot_blinken_start_dunkel gruen reserved_1	177
ROtgruen1R	rot_blinken_start_hell gruen reserved_1	178
rotgruen1R	rot gruen reserved_1	179
geLBgruen1R	gelb_blinken_start_dunkel gruen reserved_1	180
roT-geLBgruen1R	rot_blinken_start_dunkel gelb_blinken_start_dunkel gruen reserved_1	181
ROt-geLBgruen1R	rot_blinken_start_hell gelb_blinken_start_dunkel gruen reserved_1	182
rotgeLBgruen1R	rot gelb_blinken_start_dunkel gruen reserved_1	183
GEIbgruen1R	gelb_blinken_start_hell gruen reserved_1	184
roTGEIbgruen1R	rot_blinken_start_dunkel gelb_blinken_start_hell gruen reserved_1	185
ROt-GEIbgruen1R	rot_blinken_start_hell gelb_blinken_start_hell gruen reserved_1	186
rotGEIbgruen1R	rot gelb_blinken_start_hell gruen reserved_1	187
gelbgruen1R	gelb gruen reserved_1	188
roTgelbgruen1R	rot_blinken_start_dunkel gelb gruen reserved_1	189
ROtgelbgruen1R	rot_blinken_start_hell gelb gruen reserved_1	190
rotgelbgruen1R	rot gelb gruen reserved_1	191
dunkel2R	dunkel reserved_2	192

roT2R	rot_blinken_start_dunkel reserved_2	193
ROt2R	rot_blinken_start_hell reserved_2	194
rot2R	rot reserved_2	195
geLB2R	gelb_blinken_start_dunkel reserved_2	196
roTgeLB2R	rot_blinken_start_dunkel gelb_blinken_start_dunkel reserved_2	197
ROtgeLB2R	rot_blinken_start_hell gelb_blinken_start_dunkel reserved_2	198
rotgeLB2R	rot gelb_blinken_start_dunkel reserved_2	199
GEIb2R	gelb_blinken_start_hell reserved_2	200
roTGEIb2R	rot_blinken_start_dunkel gelb_blinken_start_hell reserved_2	201
ROtGEIb2R	rot_blinken_start_hell gelb_blinken_start_hell reserved_2	202
rotGEIb2R	rot gelb_blinken_start_hell reserved_2	203
gelb2R	gelb reserved_2	204
roTgelb2R	rot_blinken_start_dunkel gelb reserved_2	205
ROtgelb2R	rot_blinken_start_hell gelb reserved_2	206
rotgelb2R	rot gelb reserved_2	207
grUEN2R	gruen_blinken_start_dunkel reserved_2	208
roTgrUEN2R	rot_blinken_start_dunkel gruen_blinken_start_dunkel reserved_2	209
ROtgrUEN2R	rot_blinken_start_hell gruen_blinken_start_dunkel reserved_2	210
rotgrUEN2R	rot gruen_blinken_start_dunkel reserved_2	211
geLBgrUEN2R	gelb_blinken_start_dunkel gruen_blinken_start_dunkel reserved_2	212
roT-geLBgrUEN2R	rot_blinken_start_dunkel gelb_blinken_start_dunkel gruen_blinken_start_dunkel reserved_2	213
ROt-geLBgrUEN2R	rot_blinken_start_hell gelb_blinken_start_dunkel gruen_blinken_start_dunkel reserved_2	214

rot-geLBgrUEN2R	rot gelb_blinken_start_dunkel gruen_blinken_start_dunkel reserved_2	215
GEIbgrUEN2R	gelb_blinken_start_hell gruen_blinken_start_dunkel reserved_2	216
roT-GEIbgrUEN2R	rot_blinken_start_dunkel gelb_blinken_start_hell gruen_blinken_start_dunkel reserved_2	217
ROt-GEIbgrUEN2R	rot_blinken_start_hell gelb_blinken_start_hell gruen_blinken_start_dunkel reserved_2	218
rot-GEIbgrUEN2R	rot gelb_blinken_start_hell gruen_blinken_start_dun- kel reserved_2	219
gelbgrUEN2R	gelb gruen_blinken_start_dunkel reserved_2	220
roT-gelbgrUEN2R	rot_blinken_start_dunkel gelb gruen_blinken_start_dunkel reserved_2	221
ROt-gelbgrUEN2R	rot_blinken_start_hell gelb gruen_blinken_start_dun- kel reserved_2	222
rotgelbgrUEN2R	rot gelb gruen_blinken_start_dunkel reserved_2	223
GRuen2R	gruen_blinken_start_hell reserved_2	224
roTGRuen2R	rot_blinken_start_dunkel gruen_blinken_start_hell re- served_2	225
ROtGRuen2R	rot_blinken_start_hell gruen_blinken_start_hell re- served_2	226
rotGRuen2R	rot gruen_blinken_start_hell reserved_2	227
geLBGRuen2R	gelb_blinken_start_dunkel gruen_blinken_start_hell reserved_2	228
roT-geLBGRuen2R	rot_blinken_start_dunkel gelb_blinken_start_dunkel gruen_blinken_start_hell reserved_2	229
ROt-geLBGRuen2R	rot_blinken_start_hell gelb_blinken_start_dunkel gruen_blinken_start_hell reserved_2	230
rot-geLBGRuen2R	rot gelb_blinken_start_dunkel gruen_blinken_start_hell reserved_2	231
GEIbGRuen2R	gelb_blinken_start_hell gruen_blinken_start_hell re- served_2	232
roT-GEIbGRuen2R	rot_blinken_start_dunkel gelb_blinken_start_hell gruen_blinken_start_hell reserved_2	233

ROt-GEIbGRuen2R	rot_blinken_start_hell gelb_blinken_start_hell gruen_blinken_start_hell reserved_2	234
rot-GEIbGRuen2R	rot gelb_blinken_start_hell gruen_blinken_start_hell reserved_2	235
gelbGRuen2R	gelb gruen_blinken_start_hell reserved_2	236
roT-gelbGRuen2R	rot_blinken_start_dunkel gelb gruen_blinken_start_hell reserved_2	237
ROt-gelbGRuen2R	rot_blinken_start_hell gelb gruen_blinken_start_hell reserved_2	238
rotgelbGRuen2R	rot gelb gruen_blinken_start_hell reserved_2	239
gruen2R	gruen reserved_2	240
roTgruen2R	rot_blinken_start_dunkel gruen reserved_2	241
ROtgruen2R	rot_blinken_start_hell gruen reserved_2	242
rotgruen2R	rot gruen reserved_2	243
geLBgruen2R	gelb_blinken_start_dunkel gruen reserved_2	244
roT-geLBgruen2R	rot_blinken_start_dunkel gelb_blinken_start_dunkel gruen reserved_2	245
ROt-geLBgruen2R	rot_blinken_start_hell gelb_blinken_start_dunkel gruen reserved_2	246
rotgeLBgruen2R	rot gelb_blinken_start_dunkel gruen reserved_2	247
GEIbgruen2R	gelb_blinken_start_hell gruen reserved_2	248
roTGEIbgruen2R	rot_blinken_start_dunkel gelb_blinken_start_hell gruen reserved_2	249
ROt-GEIbgruen2R	rot_blinken_start_hell gelb_blinken_start_hell gruen reserved_2	250
rotGEIbgruen2R	rot gelb_blinken_start_hell gruen reserved_2	251
gelbgruen2R	gelb gruen reserved_2	252
roTgelbgruen2R	rot_blinken_start_dunkel gelb gruen reserved_2	253
ROtgelbgruen2R	rot_blinken_start_hell gelb gruen reserved_2	254
rotgelbgruen2R	rot gelb gruen reserved_2	255

OCIT-C_LSA_Versorgungsdaten_V2.0_R1_D1
Copyright © 2018 ODG & Partner